



LIVE CENTRES FACE DRIVERS

2015/2016

RÖHM
driven by technology

We work for customers who have a weakness for our strengths.

Companies intent on making a difference are obliged to develop constantly as well as deploy their strengths to the benefit of customers. At RÖHM, we have set ourselves high targets and are doing our very best to achieve them. This is why we support our customers all over the world by means of the six performance indicators so typical of RÖHM:



Dynamism

Variety

Security

Partnership

Globality

Innovation

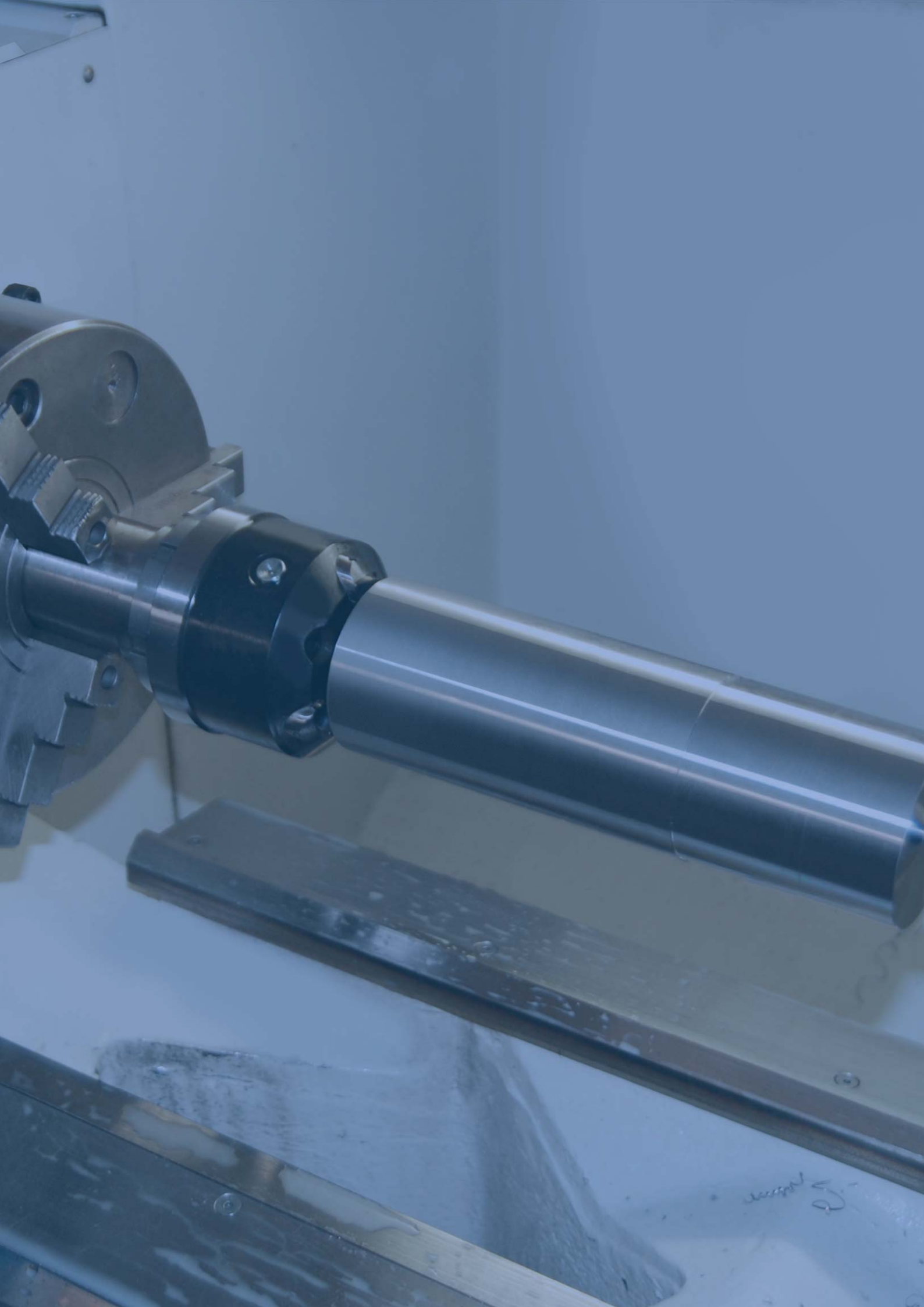

Table of contents

LIVE CENTRES | FACE DRIVERS



Live centres

Pro - carbide insert	2008
Pro - standard design	2010
Pro - cylindrical shank	2012
Pro - high precision design	2013
Pro - extended centre point	2014
Pro - profiled, extended centre point	2015
Orange Line	2016
Heavy - standard design	2017
Speed - extended centre point	2019
Slim - standard design	2020
Slim - extended centre point	2021
Slim - profiled, extended centre point	2022
Control - standard design	2023
Control - extended centre point	2024
Flex - interchangeable inserts	2025

Revolving centering taper

MZK	2030
-----	------

Dead centres

FZS	2034
-----	------

Constant face drivers

CoE	2040
CoA	2043
CoK	2052

Operation guide



PRO	HM Pro Carbide insert						HMG Pro With carbide insert and draw-off nut					
Size MT	2	3	3	4	5	6	2	3	3	4	5	6
Workpiece weight max. (kg)	120	240	360	500	1000	1800	120	240	360	500	1000	1800
Concentricity deviation max. (mm)	0,005					0,01	0,005					0,01
Speed max min ⁻¹	7000	6300	5000	3800	3000	2600	7000	6300	5000	3800	3000	2600
Page	2008						2009					



PRO	H Pro Standard design										HG Pro Standard design with draw-off nut					
Size MT	0	1	2	3	3	4	5	6	6	Metr.80	2	3	3	4	5	6
Workpiece weight max. (kg)	10	100	200	400	500	800	2000	3500	5000	7500	200	400	500	800	2000	3500
Concentricity deviation max. (mm)	0,01	0,005					0,008	0,01	0,015	0,005					0,008	
Speed max min ⁻¹	15000	7000	7000	6300	5000	3800	3000	2600	1500	1500	7000	6300	5000	3800	3000	2600
Page	2010										2011					



PRO	HZA Pro Cylindrical shank			HP Pro High precision design				
Size ZA / MT	ZA 20	ZA 25	ZA 32	2	3	4	5	6
Workpiece weight max. (kg)	130	200	400	200	500	800	2000	3500
Concentricity deviation max. (mm)	0,005			0,003				
Speed max min ⁻¹	7000	5000	3800	7000	5000	3800	3000	2600
Page	2012			2013				



PRO & ORANGE LINE	HVL Pro Extended centre point						HVLN Pro Extended centre point, profiled				Orange Line Orange Line		
Size MT	1	2	3	4	5	6	2	3	4	5	3	4	5
Workpiece weight max. (kg)	80	140	400	500	1200	2500	100	150	180	280	300	500	630
Concentricity deviation max. (mm)	0,01	0,005			0,01	0,005				0,005			
Speed max min ⁻¹	7000	7000	5000	3800	3000	2600	7000	5000	3800	3000	8500	6000	4500
Page	2014						2015				2016		

Operation guide



HEAVY SPEED	Heavy Standard design			Heavy Standard design with draw-off nut			Speed Extended centre point, with carbide insert			
Size MT	4	5	6	4	5	6	2	3	4	5
Workpiece weight max. (kg)	1000	2000	3000	1000	2000	3000	100	100	250	250
Concentricity deviation max. (mm)	0,005			0,005			0,01			
Speed max min ⁻¹	7000	6000	4800	7000	6000	4800	12000	12000	9000	9000
Page	2017			2018			2019			



SLIM	Slim Standard design					Slim Extended centre point					Slim Extended centre point, profiled			
Size MT	2	3	4	5	6	2	3	4	5	6	2	3	4	5
Workpiece weight max. (kg)	200	400	800	1600	3500	170	340	700	1400	3000	50	100	150	180
Concentricity deviation max. (mm)	0,005		0,01	0,02	0,008			0,01	0,02	0,008		0,01		
Speed max min ⁻¹	7000	7000	6300	4300	3000	7000	7000	6300	4300	3000	7000	7000	6300	4300
Page	2020					2021					2022			



CONTROL FLEX	AC Control Standard design				AC-VL Control Extended centre point				Flex Interchangeable inserts					
Size MT	3	4	5	6	3	4	5	6	2	3	3	4	5	6
Workpiece weight max. (kg)	400	800	1600	3200	260	550	1100	2500	40	130	150	250	650	900
Concentricity deviation max. (mm)	0,01		0,015		0,01		0,015		0,01					0,015
Speed max min ⁻¹	4000	3500	2500	1800	4000	3500	2500	1800	7000	6300	5000	3800	3000	2600
Page	2023				2024				2025					

Operation guide



MZK	Revolving centering tapers Pointed					
Size MT	2	3	4	5	6	
Workpiece weight max. (kg)	200	400	800	1600	2500	
Concentricity deviation max. (mm)	0,01		0,008			
Speed max min ⁻¹	6000	6000	4000	4000	2500	
Page	2030					



MZK	Revolving centering tapers Cone truncated, 60 °						
Size MT	2	2	3	3	4	4	5
Workpiece weight max. (kg)	200	300	400	600	400	800	800
Concentricity deviation max. (mm)	0,008						
Speed max min ⁻¹	6000	5000	5000	4000	5000	4000	4000
Page	2030						



MZK	Revolving centering tapers Cone truncated, 75 °											
Size MT	2	3	3	4	4	4	5	5	5	6	6	6
Workpiece weight max. (kg)	300	400	600	400	800	1200	800	1600	2000	1600	2000	4000
Concentricity deviation max. (mm)	0,008					0,01	0,008	0,01				0,015
Speed max min ⁻¹	5000	5000	4000	5000	4000	2800	4000	2800	2200	2800	2200	1200
Page	2030											



MZK	Revolving centering tapers with interchangeable inserts			Revolving centering tapers with interchangeable inserts and draw-off nut			Fixed shafts with interchangeable inserts		
Size MT	4	5	6	4	5	6	4	5	6
Workpiece weight max. (kg)	800	1600	3000	1000	2000	3500	2000	4800	12000
Concentricity deviation max. (mm)	0,005			0,005			0,003		
Speed max min ⁻¹	3800	3000	2600	7000	6000	4800	-	-	-
Page	2031			2031			2031		

Operation guide



FZS	Dead centres With full carbide tip				Dead centres Full point, carbide insert and regrinding line			
Size MT	2	3	4	5	2	3	4	5
Concentricity deviation max. (mm)	0,005				0,005			
Page	2034				2034			



FZS	Dead centres Full point						
Size MT	0	1	2	3	4	5	6
Concentricity deviation max. (mm)	0,005						
Page	2034						



FZS	Dead centres Full point, draw-off nut and SW				Dead centres Full point, draw-off nut, SW and extended point			
Size MT	3	4	5	6	3	4	5	6
Concentricity deviation max. (mm)	0,005				0,005			
Page	2035				2035			



FZS	Dead centres Half point with carbide insert				Dead centres Half point			
Size MT	2	3	4	5	2	3	4	5
Concentricity deviation max. (mm)	0,005				0,01			
Page	2035				2035			

Dead centres in high precision design on request.



THE RIGHT LIVE CENTRE FOR EVERY APPLICATION

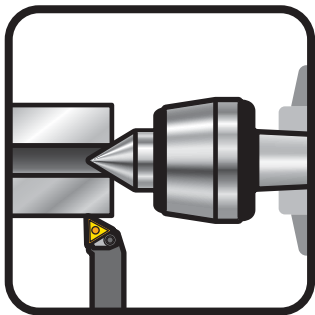

For small and large centres

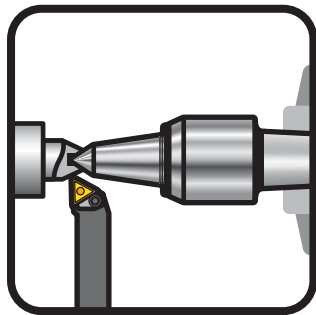

For cramped work area

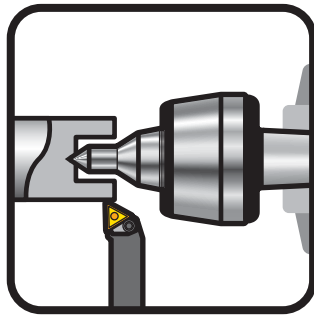

For lower-lying centres

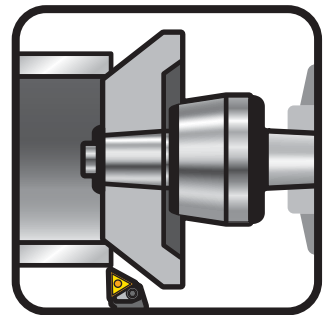

For large boreholes

LIVE CENTRES

The requirement for high cutting capacities and high working precision demands an additional support by a revolving live centre for many workpieces due to their shape and length. Thanks to their precision bearings, RÖHM live centres offer optimal force absorption and a maximum concentricity deviation of up to 0.003 mm. Thanks to the lifetime lubrication, the centre points are maintenance-free.

ADVANTAGES AT A GLANCE

- ⊕ Maximum concentricity and optimal force absorption thanks to proven precision bearings
- ⊕ Special lubrication for long service life and little required maintenance
- ⊕ Minimum interference contour thanks to slender housing shape

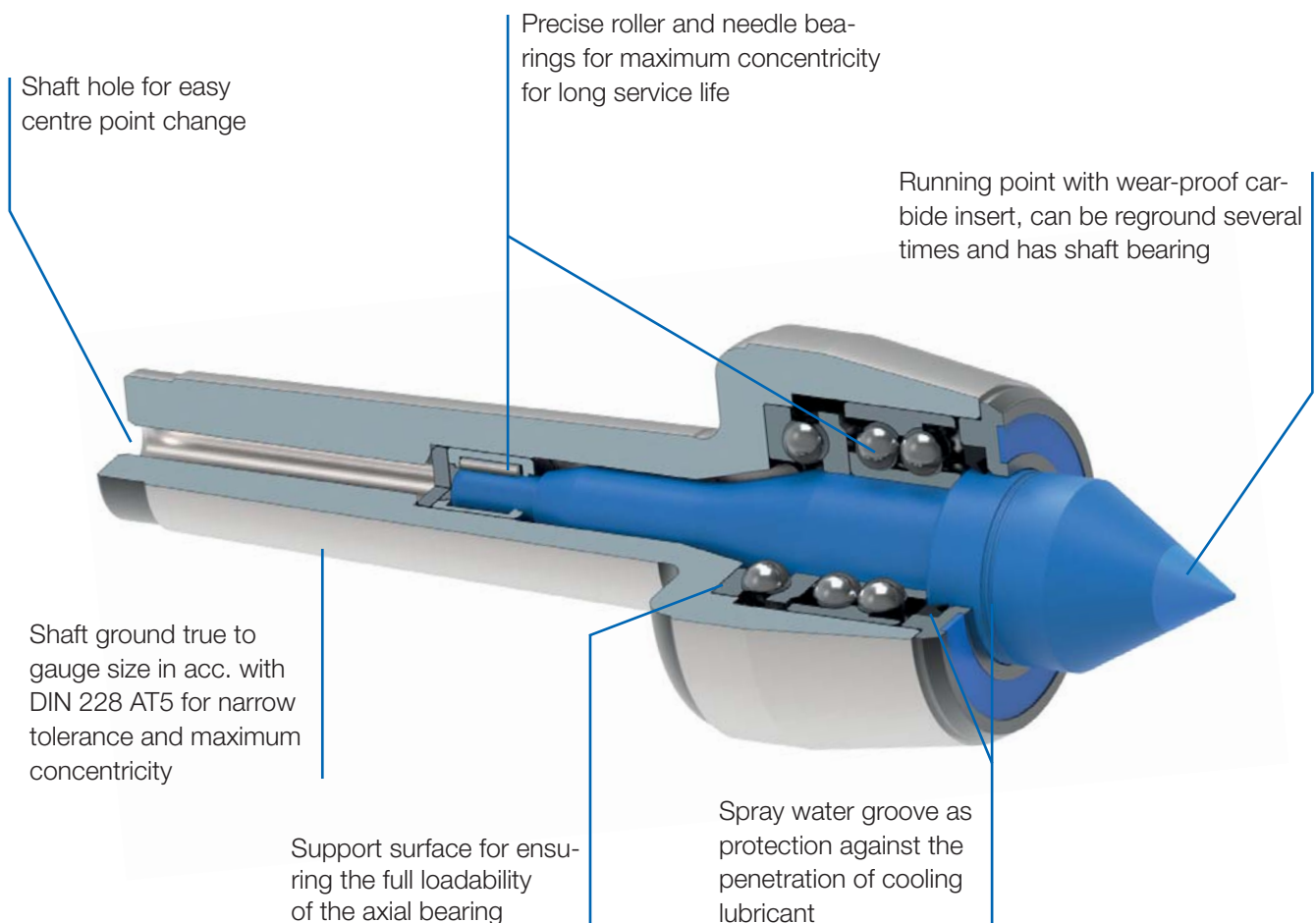

Pro - carbide insert

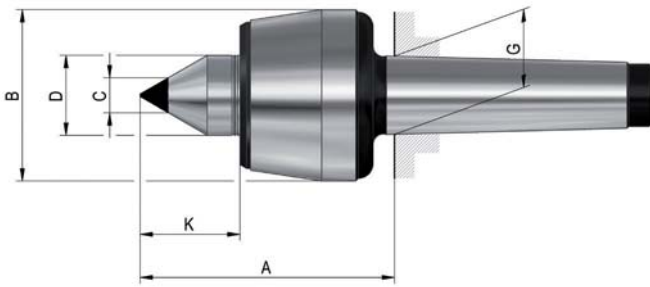

APPLICATION

For counter-clamping workpieces on turning and grinding machines.

TYPE

Centre point with wear-proof carbide insert.

CUSTOMER BENEFITS

- ⊕ Maximum service life and wear resistance thanks to carbide insert
- ⊕ High concentricity and stability thanks to 3-fold bearing
- ⊕ Maximum concentricity deviation of 0.005 mm for maximum precision

TECHNICAL FEATURES

- Body hardened and ground
- Tip angle 60°

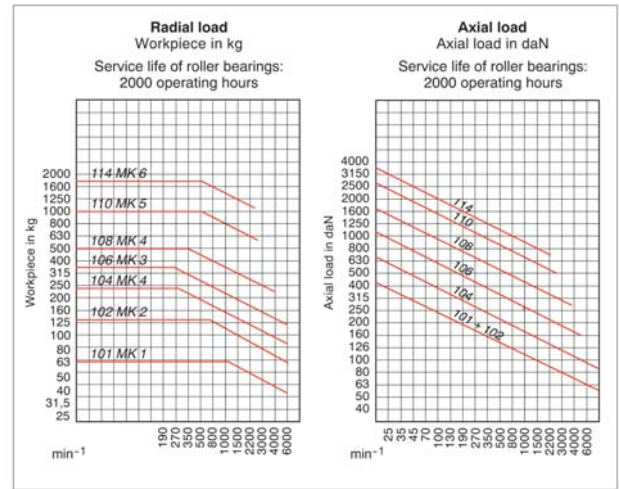

A06
HM Pro **with carbide insert**, body hardened and ground - tip angle 60°

Item no.	032140	090089	237413	093306	221016	221017
Mount MT	2	3	3	4	5	6
Size	102	104	106	108	110	114
A mm	65	70,5	79,5	102,5	129	152
B mm	43	48,5	58,5	68,5	88,5	102,5
C mm	11	11	14	14	18	18
D mm	20	22	25	32	40	50
G mm	17,78	23,825	23,825	31,267	44,399	63,348
K mm	24	27	30,5	40	49,5	57
Weight approx. g	600	900	1300	2300	4700	10000
Workpiece weight max. kg	120	240	360	500	1000	1800
Concentricity deviation max. mm	0,005	0,005	0,005	0,005	0,005	0,01
Speed max. min ⁻¹	7000	6300	5000	3800	3000	2600
Spare live centres	1241742	1241743	1241744	1241745	1241746	1241747

Pro - carbide insert

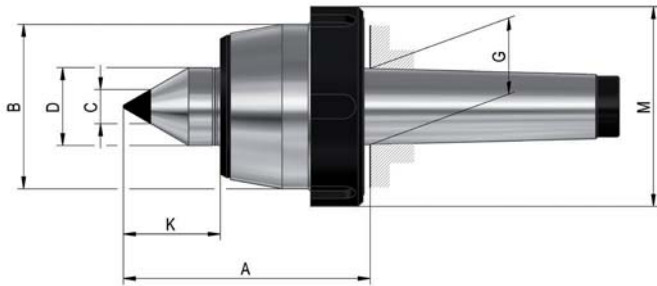

APPLICATION

For counter-clamping workpieces on turning and grinding machines.

TYPE

Centre point with wear-proof carbide insert.
With draw-off nut.

CUSTOMER BENEFITS

- ⊕ Maximum service life and wear resistance thanks to carbide insert
- ⊕ High concentricity and stability thanks to 3-fold bearing
- ⊕ Maximum concentricity deviation of 0.005 mm for maximum precision

TECHNICAL FEATURES

- Body hardened and ground
- Tip angle 60°

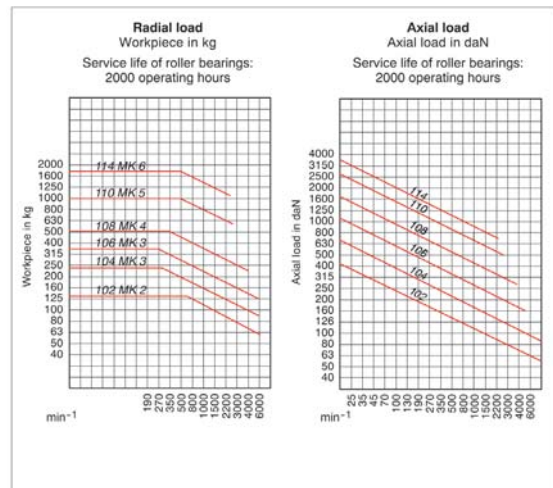

A06
HMG Pro with draw-off nut and carbide insert, body hardened and ground - tip angle 60°

Item no.	221021	221022	221023	221024	221025	221026
Mount MT	2	3	3	4	5	6
Size	102	104	106	108	110	114
A mm	65	70,5	79,5	102,5	129	152
B mm	45	50	60	70	90	105
C mm	11	11	14	14	18	18
D mm	20	22	25	32	40	50
G mm	17,78	23,825	23,825	31,265	44,399	63,348
K mm	24	27	30,5	40	49,5	57
M mm	56	62	74	82	105	120
Weight approx. g	600	1000	1400	2400	5200	10500
Workpiece weight max. kg	120	240	360	500	1000	1800
Concentricity deviation max. mm	0,005	0,005	0,005	0,005	0,005	0,01
Speed max. min ⁻¹	7000	6300	5000	3800	3000	2600
Spare live centres	1241742	1241743	1241744	1241745	1241746	1241747

Pro - standard design

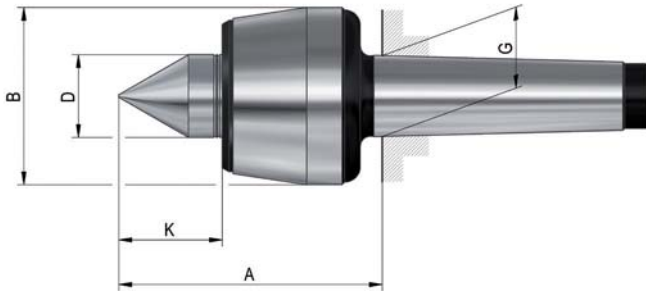

APPLICATION

For counter-clamping workpieces on turning and grinding machines.

TYPE

All-round live centre in classical design for nearly any standard clamping situation.

CUSTOMER BENEFITS

- ⊕ Proven 3-fold bearing for high axial and radial load
- ⊕ Lifetime lubrication for minimum required maintenance
- ⊕ Maximum concentricity deviation of 0.005 mm for maximum precision

TECHNICAL FEATURES-

- Body hardened and ground (MT 1 - Metr. 80)
- Tip angle 60°

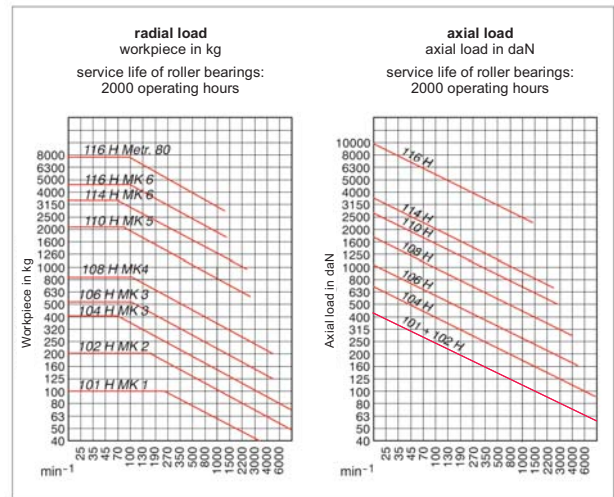

A06
H Pro, body hardened and ground - tip angle 60°

Item no.	061740 ¹⁾	043400	043115	042315	042776	042175	042843	043532	093439	093440
Mount MT	0	1	2	3	3	4	5	6	6	Metr. 80
Size	100	101	102	104	106	108	110	114	116	116
A mm	44	60,5	65	70,5	79,5	102,5	129	152	196	196
B mm	25	34,5	43	48,5	58,5	68,5	88,5	102,5	138,5	138,5
D mm	10	15	20	22	25	32	40	50	60	60
G mm	9,045	12,065	17,78	23,825	23,825	31,267	44,399	63,348	63,348	80
K mm	11	17	24	27	30,5	40	49,5	57	66	66
Weight approx. g	200	400	500	800	1300	2300	4700	10200	17800	23000
Workpiece weight max. kg	10	100	200	400	500	800	2000	3500	5000	7500
Concentricity deviation max. mm	0,01	0,005	0,005	0,005	0,005	0,005	0,005	0,008	0,01	0,015
Speed max. min ⁻¹	15000	7000	7000	6300	5000	3800	3000	2600	1500	1500
Spare live centres	1241727	1241726	1241725	1241724	1241723	1241722	1241721	1241728	1241729	1241730

1) body only ground not hardened

Pro - standard design

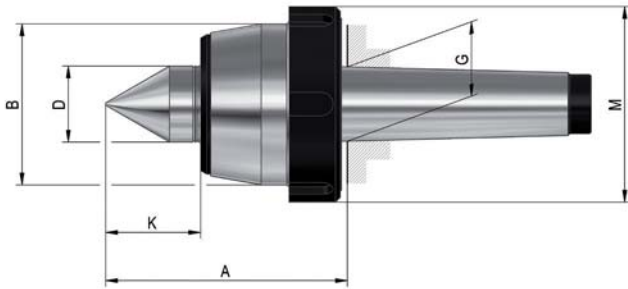

APPLICATION

For counter-clamping workpieces on turning and grinding machines.

TYPE

All-round live centre in classical design for nearly any standard clamping situation. With draw-off nut.

CUSTOMER BENEFITS

- ⊕ Proven 3-fold bearing for high axial and radial load
- ⊕ Lifetime lubrication for minimum required maintenance
- ⊕ Maximum concentricity deviation of 0.005 mm for maximum precision

TECHNICAL FEATURES

- Body hardened and ground (MT 2 - 6)
- Tip angle 60°

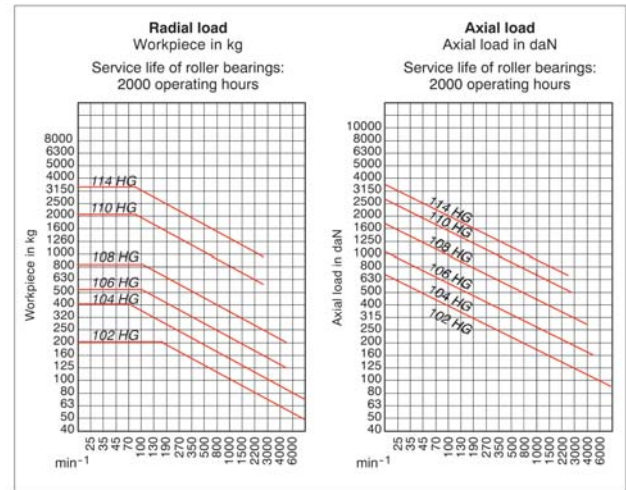

A06
HG Pro, with draw-off nut, body hardened and ground - tip angle 60°

Item no.	221018	221019	205036	207148	074390	221020
Mount MT	2	3	3	4	5	6
Size	102	104	106	108	110	114
A mm	65	70,5	79,5	102,5	129	152
B mm	45	50	60	70	90	105
D mm	20	22	25	32	40	50
G mm	17,78	23,825	23,825	31,267	44,399	63,348
K mm	24	27	30,5	40	49,5	57
M mm	56	62	74	82	105	120
Weight approx. g	600	1000	1400	2400	5200	10500
Workpiece weight max. kg	200	400	500	800	2000	3500
Concentricity deviation max. mm	0,005	0,005	0,005	0,005	0,005	0,008
Speed max. min ⁻¹	7000	6300	5000	3800	3000	2600
Spare live centres	1241725	1241724	1241723	1241722	1241721	1241728

Pro - cylindrical shank



APPLICATION

For the counter-clamping of workpieces on turning and grinding machines using rotary chucks, collet chucks and tool take-ups. Take-up for tool magazine / turret.

TYPE

All-round live centre with cylindrical shank.

CUSTOMER BENEFITS

- ③ Proven 3-fold bearing for high axial and radial load
- ③ Lifetime lubrication for minimum required maintenance
- ③ Maximum concentricity deviation of 0.005 mm for maximum precision

TECHNICAL FEATURES

- Body hardened and ground
- Tip angle 60°

Note:

Live centres with cylindrical shank and clamping surface on request

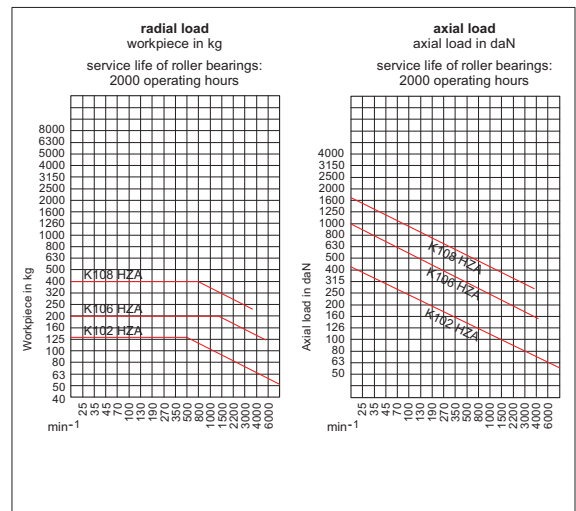
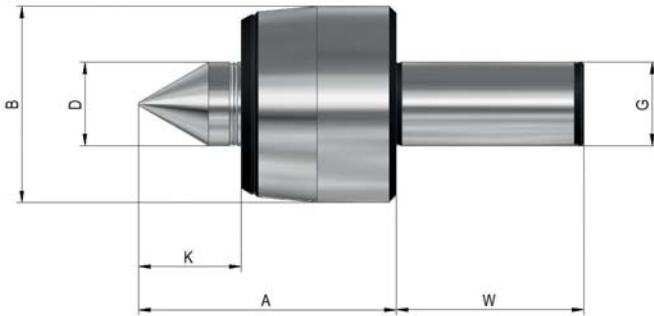

A06
HZA Pro with cylindrical shank, body hardened and ground - tip angle 60°

Item no.	1316054	1316055	1316056
Mount MT	ZA20	ZA25	ZA32
Size	102	106	108
A mm	58	76,8	93,1
B mm	43	48,5	68,5
D mm	20	25	32
G mm	20	25	32
K mm	24	30,5	40
Weight approx. g	414	891	1474
Workpiece weight max. kg	130	200	400
Concentricity deviation max. mm	0,005	0,005	0,005
Speed max. min ⁻¹	7000	5000	3800
Spare live centres	1241725	1241723	1241722

Pro - high precision design



APPLICATION

For counter-clamping workpieces on turning and grinding machines for highest demands.

TYPE

High precision design.

CUSTOMER BENEFITS

- ⊕ Maximum concentricity deviation of **0.003 mm** for maximum precision
- ⊕ Lifetime lubrication for minimum required maintenance
- ⊕ Proven 3-fold bearing for high axial and radial load

TECHNICAL FEATURES

- Body hardened and ground
- Tip angle 60°

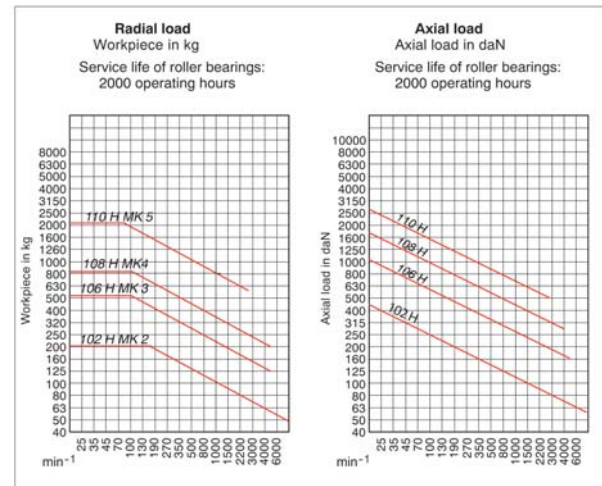
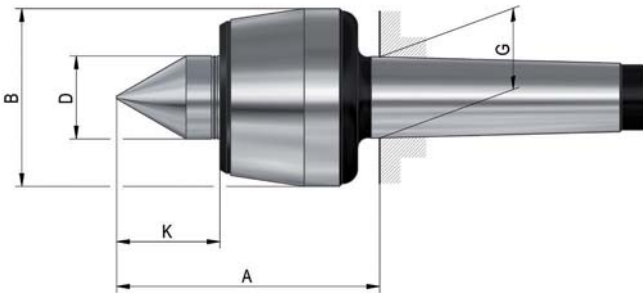

A06
HP Pro **precision version**, body hardened and ground - tip angle 60°

Item no.	082392	318227	082394	082395	1263871
Mount MT	2	3	4	5	6
Size	102	106	108	110	114
A mm	65	82	102,5	129	151,6
B mm	43	55	68,5	88,5	102,5
D mm	20	25	32	40	50
G mm	17,78	23,825	31,267	44,399	63,348
K mm	24	30,5	40	49,5	56,9
Weight approx. g	500	1300	2300	4700	8761
Workpiece weight max. kg	200	500	800	2000	3500
Concentricity deviation max. mm	0,003	0,003	0,003	0,003	0,003
Speed max. min ⁻¹	7000	5000	3800	3000	2600
Spare live centres	1241725	1243613	1241722	1241721	1241728

Pro - extended centre point

Live centres



APPLICATION

For counter-clamping workpieces on turning and grinding machines. Especially suited for cramped work area between centre point and workpiece.

TYPE

All-round live centre with extended centre point.

CUSTOMER BENEFITS

- ⊕ Enlarged work area and better workpiece accessibility thanks to profiled centre point
- ⊕ High concentricity and stability thanks to 3-fold bearing
- ⊕ Maximum concentricity deviation of 0.005 mm for maximum precision

TECHNICAL FEATURES

- Body hardened and ground
- Tip angle 60°

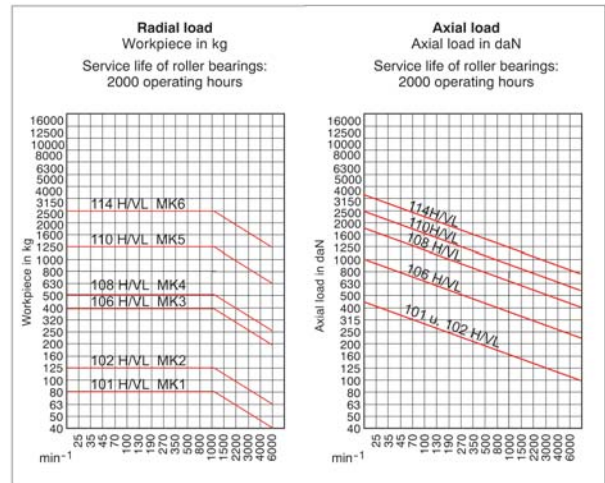
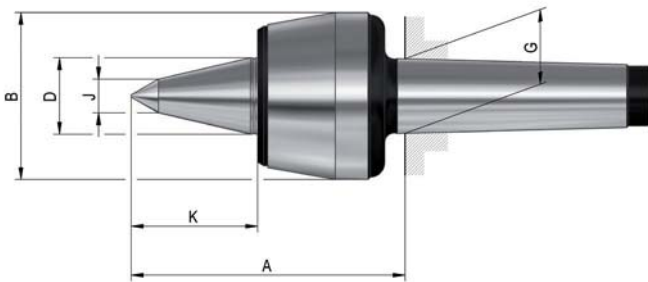

A06
HVL Pro with extended centre point, body hardened and ground - tip angle 60°

Item no.	058668	058669	058670	058671	058672	058673
Mount MT	1	2	3	4	5	6
Size	101	102	106	108	110	114
A mm	70,5	75	95,5	114,5	143,5	172,5
B mm	34,5	43	58,5	68,5	88,5	102,5
D mm	15	20	25	32	40	50
G mm	12,065	17,78	23,825	31,267	44,399	63,348
K mm	27	34	47	53	64	78
J mm	9	10	12	14	16	18
Weight approx. g	400	500	1300	2300	4800	10200
Workpiece weight max. kg	80	140	400	500	1200	2500
Concentricity deviation max. mm	0,01	0,005	0,005	0,005	0,005	0,01
Speed max. min ⁻¹	7000	7000	5000	3800	3000	2600
Spare live centres	1241731	1241732	1241733	1241734	1241735	1241736

Pro - profiled, extended centre point



APPLICATION

For counter-clamping workpieces on turning and grinding machines. Especially suited for cramped work area between centre point and workpiece as well as low-lying workpiece centres.

TYPE

All-round live centre with profiled centre point.

CUSTOMER BENEFITS

- ① Enlarged work area and better workpiece accessibility thanks to profiled centre point
- ② High concentricity and stability thanks to 3-fold bearing
- ③ Maximum concentricity deviation of 0.005 mm for maximum precision

TECHNICAL FEATURES

- Body hardened and ground
- Tip angle 60°

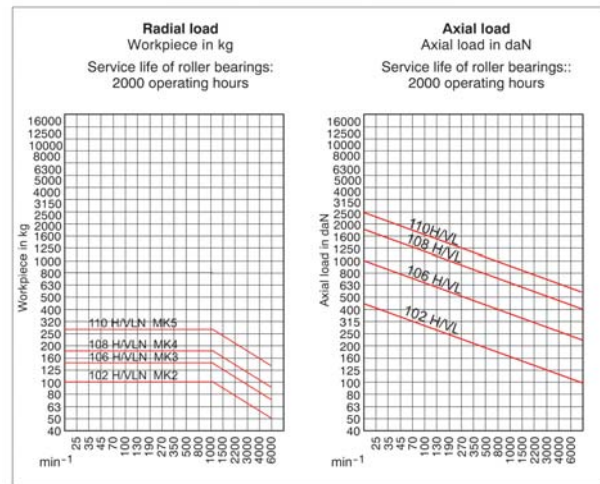
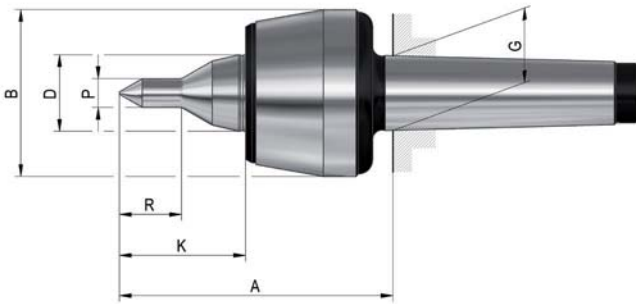

A06
HVLN Pro with profiled, extended centre point, body hardened and ground - tip angle 60°

Item no.	1241689	1241691	1241693	1241694
Mount MT	2	3	4	5
Size	102	106	108	110
A mm	75	95,5	114,5	143,5
B mm	43	58,5	68,5	88,5
D mm	20	25	32	40
G mm	17,78	23,825	31,267	44,399
K mm	34	47	53	64
P mm	8	10	12	14
R mm	16	20	26	30
Workpiece weight max. kg	100	150	180	280
Concentricity deviation max. mm	0,005	0,005	0,005	0,005
Speed max. min ⁻¹	7000	5000	3800	3000
Weight approx. g	320	460	1000	2600
Spare live centres	1243677	1243678	1243679	1243680

Orange Line

Live centres

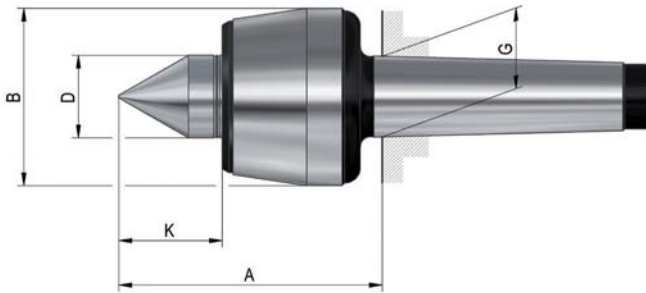

APPLICATION

For counter-clamping workpieces on turning and grinding machines.

TYPE

All-round live centre in classical design for all basic requirements for turning machining.

CUSTOMER BENEFITS

- ⊕ Running tip through-hardened, and therefore can be reground as desired
- ⊕ Lifetime lubrication for minimum required maintenance
- ⊕ Good price/performance ratio

TECHNICAL FEATURES

- Body ground
- Tip angle 60°

Note:

For higher rotation speed at reduced lateral load

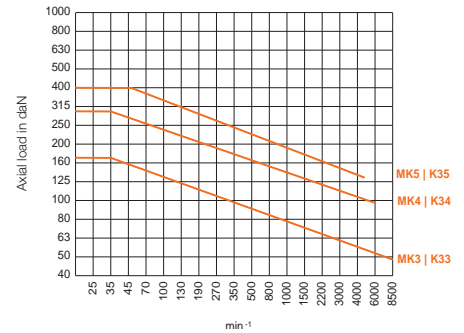
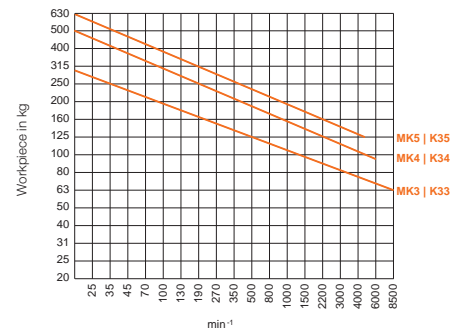

A06
Orange Line, body only ground - tip angle 60°

Item no.	1267217	1267218	1267219
Mount MT	3	4	5
Size	K33	K34	K35
A mm	82,5	101,5	128
B mm	55	68,5	88,5
D mm	25	32	40
G mm	23,825	31,267	44,399
K mm	30	40	49,5
Weight approx. g	1000	1800	4300
Workpiece weight max. kg	300	500	630
Concentricity deviation max. mm	0,005	0,005	0,005
Speed max. min ⁻¹	8500	6000	4500
Spare live centres	1243613	1241722	1241721

Heavy - standard design



APPLICATION

For counter-clamping especially heavy workpieces on turning and grinding machines.
Especially suitable for use on NC-machines.

TYPE

Universal version with extended centre point for heavy workpieces.

CUSTOMER BENEFITS

- ⊕ Robust 4-fold precision bearing for high speeds as well as high axial and radial loads
- ⊕ Reliable and safe clamping of heavy workpieces
- ⊕ Maximum concentricity deviation of 0.005 mm for maximum precision

TECHNICAL FEATURES

- Body hardened and ground
- Tip angle 60°

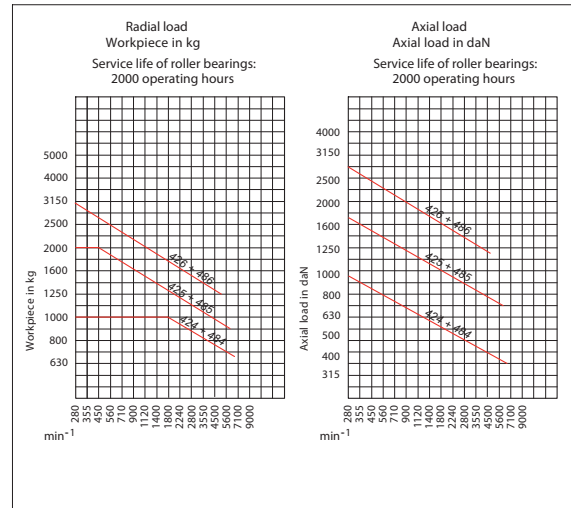
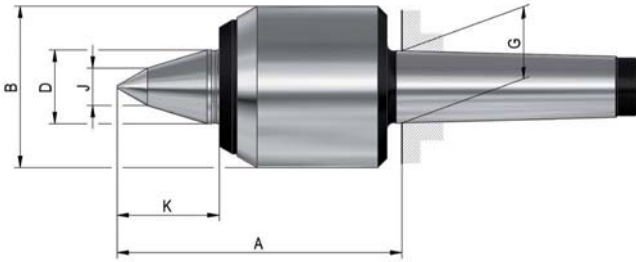

A06
Heavy especially for high load at high speeds, body hardened and ground - tip angle 60°

Item no.	303598	303599	301696
Mount MT	4	5	6
Size	424	425	426
A mm	122	150	180
B mm	70	95	120
D mm	32	42	58
G mm	31,267	44,399	63,348
J mm	16	20	26
K mm	44,5	59,5	76
Weight approx. g	2600	5500	11500
Workpiece weight max. kg	1000	2000	3000
Concentricity deviation max. mm	0,005	0,005	0,005
Speed max. min ⁻¹	7000	6000	4800
Spare live centres	1241762	1241763	1241764

Heavy - standard design

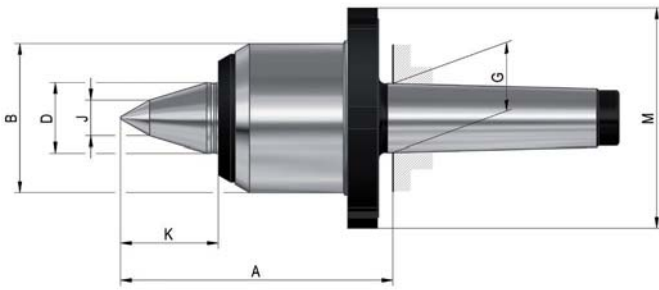

APPLICATION

For counter-clamping especially heavy workpieces on turning and grinding machines. Especially suitable for use on NC-machines.

TYPE

Universal version with extended centre point for heavy workpieces. With draw-off nut.

CUSTOMER BENEFITS

- ③ Robust 4-fold precision bearing for high speeds as well as high axial and radial loads
- ③ Reliable and safe clamping of heavy workpieces
- ③ Maximum concentricity deviation of 0.005 mm for maximum precision

TECHNICAL FEATURES

- Body hardened and ground
- Tip angle 60°

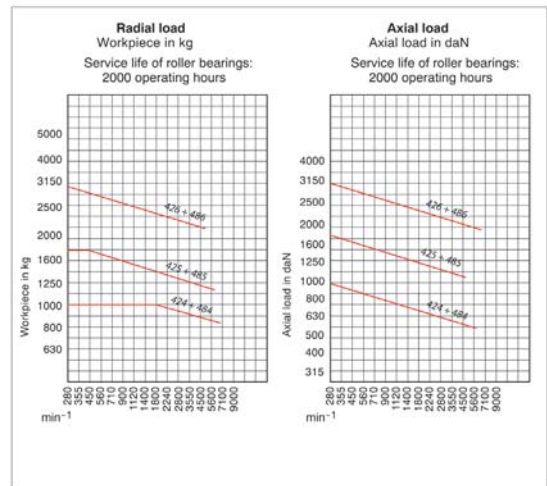

A06
Heavy with draw-off nut, especially for high load at high speeds, body hardened and ground - tip angle 60°

Item no.	304521	304522	304523
Mount MT	4	5	6
Size	484	485	486
A mm	122	150	180
B mm	70	95	120
D mm	32	42	58
G mm	31,267	44,399	63,348
J mm	16	20	26
K mm	44,5	59,5	76
M mm	100	125	155
Weight approx. g	2800	5400	12300
Workpiece weight max. kg	1000	2000	3000
Concentricity deviation max. mm	0,005	0,005	0,005
Speed max. min ⁻¹	7000	6000	4800
Spare live centres	1241762	1241763	1241764

Speed - extended centre point



APPLICATION

For counter-clamping workpieces on turning and grinding machines. Especially suitable for complex machining at high speeds.

TYPE

Special design for very high speeds with extended centre point and wear-resistant carbide insert.

CUSTOMER BENEFITS

- ⊕ Maximum rigidity for high speeds up to 12000 rpm thanks to compact design
- ⊕ Enlarged work area and better workpiece accessibility thanks to profiled centre point
- ⊕ Maximum concentricity deviation of 0.01 mm for maximum precision

TECHNICAL FEATURES

- Body hardened and ground
- Tip angle 60°

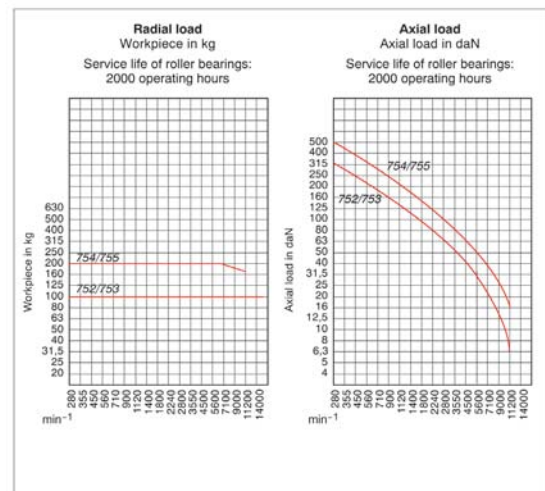
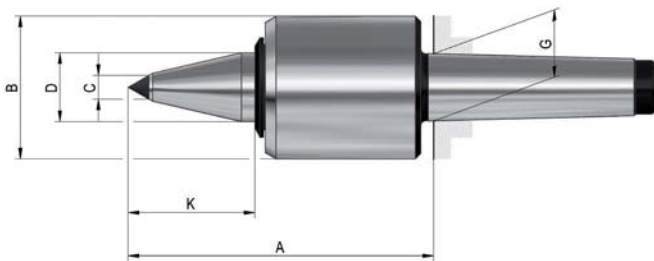

A06

Speed extended NC-centre point with carbide insert, for high speed body, hardened and ground - tip angle 60°

Item no.	772389	772390	772391	772392
Mount MT	2	3	4	5
Size	752	753	754	755
A mm	99	99	141	141
B mm	45	45	66	66
C mm	7	7	11	11
D mm	20	20	32	32
G mm	17,78	23,825	31,267	44,399
K mm	40	40	63	63
Weight approx. g	1200	1600	2600	5000
Workpiece weight max. kg	100	100	250	250
Concentricity deviation max. mm	0,01	0,01	0,01	0,01
Speed max. min ⁻¹	12000	12000	9000	9000
Spare live centres	790267	790267	790291	790291

Slim - standard design

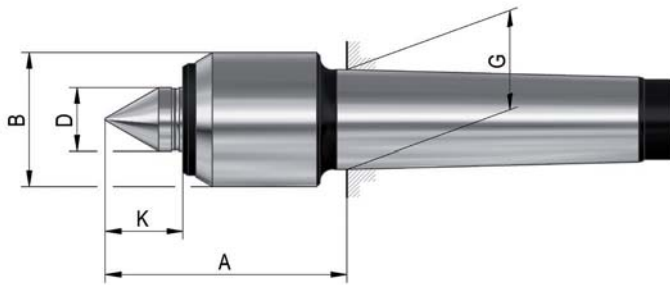

APPLICATION

For counter-clamping workpieces on turning and grinding machines. Especially suited for cramped work area between centre point and workpiece.

TYPE

Compact design with minimum casing diameter.

CUSTOMER BENEFITS

- ③ Enlarged work area and better workpiece accessibility thanks to narrow casing diameter
- ③ Maximum rigidity at high speeds thanks to compact design
- ③ Maximum concentricity deviation of 0.005 mm for maximum precision

TECHNICAL FEATURES

- Body hardened and ground
- Tip angle 60°

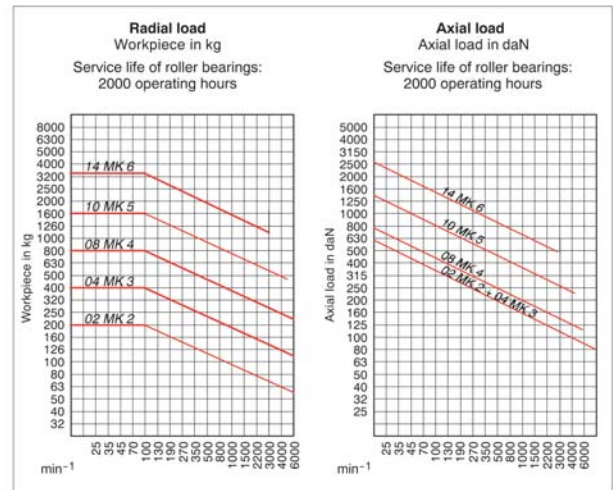

A06
Slim with small casing diameter, body hardened and ground - tip angle 60°

Item no.	005336	005429	005469	005490	005547
Mount MT	2	3	4	5	6
Size	02	04	08	10	14
A mm	62	62	75,5	106	143
B mm	32	34	42	58	80
D mm	15	15	20	30	42
G mm	17,78	23,825	31,267	44,399	63,348
K mm	19,5	19,5	24,5	37	49,5
Weight approx. g	300	400	1000	2600	7100
Workpiece weight max. kg	200	400	800	1600	3500
Concentricity deviation max. mm	0,005	0,005	0,005	0,01	0,02
Speed max. min ⁻¹	7000	7000	6300	4300	3000
Spare live centres	1241748	1241749	1241750	1241751	1241752

Slim - extended centre point

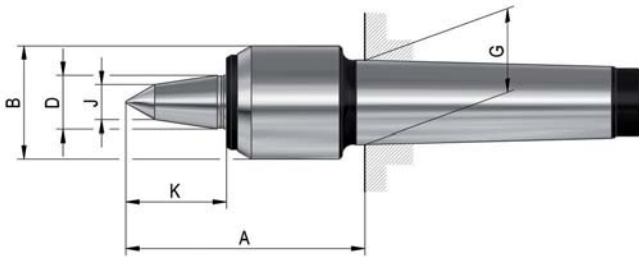

APPLICATION

For counter-clamping workpieces on turning and grinding machines. Especially suited for cramped work area between centre point and workpiece as well as low-lying workpiece centres.

TYPE

Compact design with minimum casing diameter. With extended centre point.

CUSTOMER BENEFITS

- ③ Enlarged work area and better workpiece accessibility thanks to narrow casing diameter and extended centre point
- ③ Maximum rigidity at high speeds thanks to compact design
- ③ Maximum concentricity deviation of 0.008 mm for maximum precision

TECHNICAL FEATURES

- Body hardened and ground
- Tip angle 60°

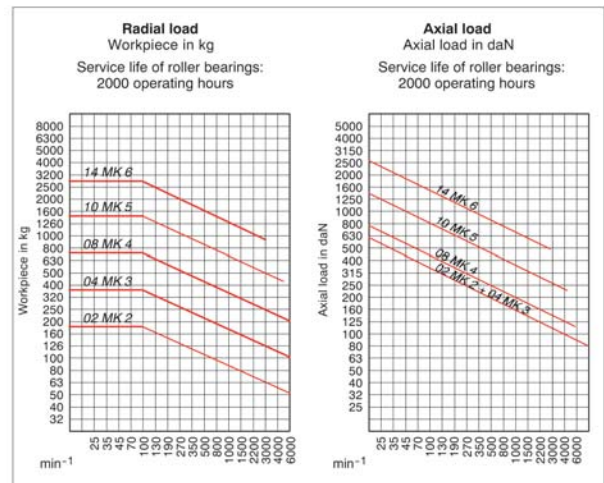

A06

Slim with small casing diameter and extended centre point, body hardened and ground - tip angle 60°

Item no.	362080	362081	362082	362083	362084
Mount MT	2	3	4	5	6
Size	02	04	08	10	14
A mm	73	74	88,5	119	164
B mm	32	34	42	58	80
D mm	15	15	20	30	42
G mm	17,78	23,825	31,267	44,399	63,348
K mm	29,5	32	37,5	51,5	70,5
J mm	10	11	13	14	18
Weight approx. g	320	460	1000	2600	7100
Workpiece weight max. kg	170	340	700	1400	3000
Concentricity deviation max. mm	0,008	0,008	0,008	0,01	0,02
Speed max. min ⁻¹	7000	7000	6300	4300	3000
Spare live centres	1241753	1241754	1241755	1241756	1241757

Slim - profiled, extended centre point



APPLICATION

For counter-clamping workpieces on turning and grinding machines. Especially suited for cramped work area between centre point and workpiece.

TYPE

Compact design with minimum casing diameter. With extended and profiled centre point.

CUSTOMER BENEFITS

- ③ Enlarged work area and better workpiece accessibility thanks to narrow casing diameter and extended and profiled centre point
- ③ Maximum rigidity at high speeds thanks to compact design
- ③ Maximum concentricity deviation of 0.008 mm for maximum precision

TECHNICAL FEATURES

- Body hardened and ground
- Tip angle 60°

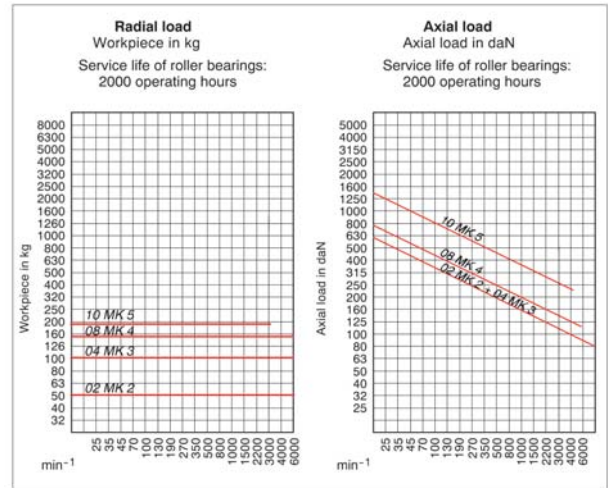
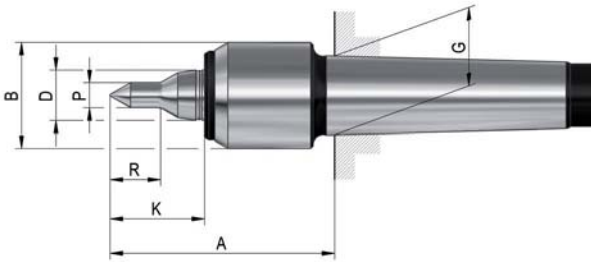

A06
Slim with small casing diameter and profiled and extended centre point, body hardened and ground - tip angle 60°

Item no.	1241695	1243505	1243507	1243509
Mount MT	2	3	4	5
Size	02	04	08	10
A mm	73	74	88,5	119
B mm	32	34	42	58
D mm	15	15	20	30
G mm	17,78	23,825	31,267	44,399
K mm	29,5	32	37,5	51,5
P mm	6	8	10	12
R mm	12	16	20	26
Workpiece weight max. kg	50	100	150	180
Concentricity deviation max. mm	0,008	0,008	0,008	0,01
Speed max. min ⁻¹	7000	7000	6300	4300
Weight approx. g	320	460	1000	2600
Spare live centres	1241758	1241759	1241760	1241761

Control - standard design

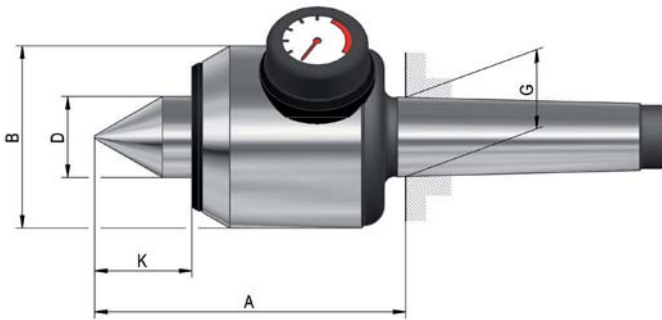

APPLICATION

For counter-clamping workpieces on turning and grinding machines. Optimally suited as counter-centre for face drivers.

TYPE

With pressure display and length compensation.

CUSTOMER BENEFITS

- ⊕ Fast adjustment and check of axial load by means of pressure display
- ⊕ Resilient centre point for safe, deformation-free workpiece clamping
- ⊕ Maximum concentricity deviation of 0.01 mm for maximum precision

TECHNICAL FEATURES

- Body hardened and ground
- Tip angle 60°

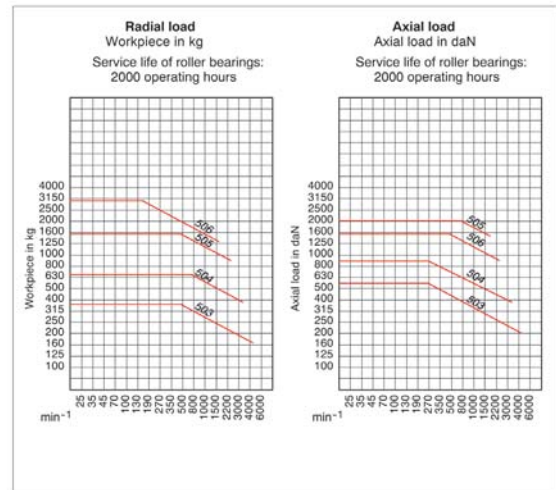

A06

AC Control with pressure display and length compensation, as counter-centre for face drivers, body hardened and ground - tip angle 60°

Item no.	060798	060874	060906	060915
Mount MT	3	4	5	6
Size	503	504	505	506
A mm	105	123,5	160,5	202
B mm	64	72	95	120
D mm	25	32	40	52
G mm	23,825	31,267	44,399	63,348
K mm	31	38,5	49	59
Weight approx. g	2100	3500	8300	17000
Spring way max. mm ¹⁾	1,6	2	1,8	2,7
Axial load max. N	5500	9000	15000	20000
Workpiece weight max. kg	400	800	1600	3200
Concentricity deviation max. mm	0,01	0,01	0,01	0,015
Speed max. min ⁻¹	4000	3500	2500	1800
Spare live centres	009192	009205	009325	009413

¹⁾ at max. axial load

Control - extended centre point

Live centres



APPLICATION

For counter-clamping workpieces on turning and grinding machines. Especially suited as counter-centre for face drivers as well as for cramped work area between centre point and workpiece.

TYPE

With pressure display, length compensation and extended live centre.

CUSTOMER BENEFITS

- ② Fast adjustment and check of axial load by means of pressure display
- ② Enlarged work area and better workpiece accessibility thanks to extended centre point
- ② Resilient live centre for safe, deformation-free workpiece clamping
- ② Maximum concentricity deviation of 0.01 mm for maximum precision

TECHNICAL FEATURES

- Body hardened and ground
- Tip angle 60°

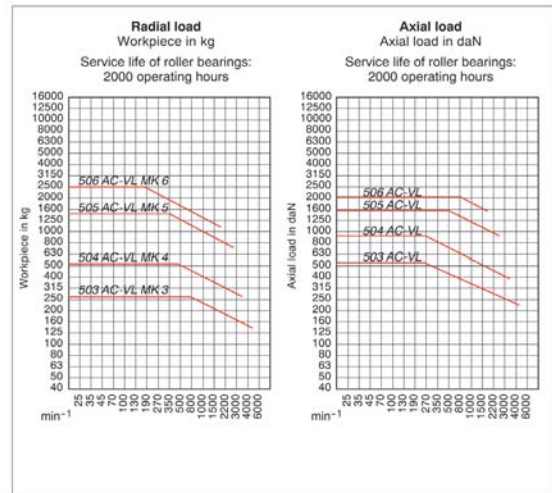
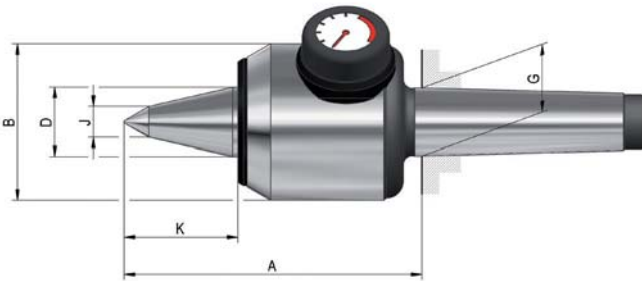

A06
AC-VL Control with **pressure display, length compensation and extended centre point**, as counter-centre for face drivers, body hardened and ground - tip angle 60°

Item no.	079920	079921	079922	079923
Mount MT	3	4	5	6
Size	503	504	505	506
A mm	120	137,5	177,5	223
B mm	64	72	95	120
D mm	25	32	40	52
G mm	23,825	31,267	44,399	63,348
K mm	45,5	52,5	66	80
J mm	11	14	15	24
Weight approx. g	2200	3600	8400	17500
Spring way max. mm ¹⁾	1,6	2	1,8	2,7
Axial load max. N	5500	9000	15000	20000
Workpiece weight max. kg	260	550	1100	2500
Concentricity deviation max. mm	0,01	0,01	0,01	0,015
Speed max. min ⁻¹	4000	3500	2500	1800
Spare live centres	079924	079925	079926	079927

¹⁾ at max. axial load

Flex - interchangeable inserts



APPLICATION

For counter-clamping workpieces on turning and grinding machines.

TYPE

With interchangeable inserts made of wear-resistant tool steel for maximum flexibility.

CUSTOMER BENEFITS

- ② Wide range of applications thanks to interchangeable inserts
- ② Quick change of interchangeable inserts

TECHNICAL FEATURES

- Body hardened and ground
- Inserts through-hardened and ground

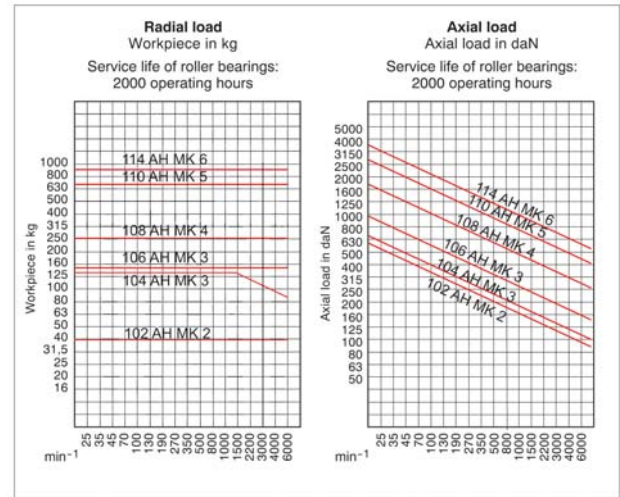
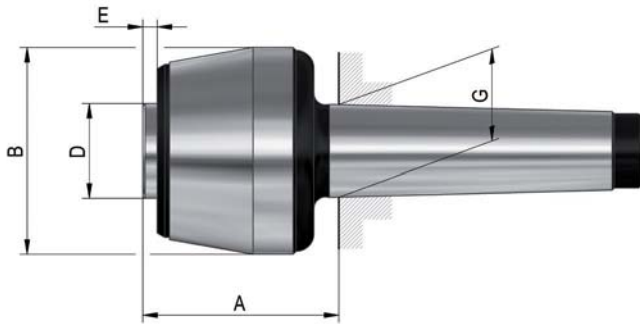

A06

Flex for **interchangeable inserts**, body hardened and ground

Item no.	061030	061031	061032	061038	061039	061040
Mount MT	2	3	3	4	5	6
Size	102	104	106	108	110	114
A mm	45	48	55	67	85	101
B mm	43	48,5	58,5	68,5	88,5	102,5
D mm	20	22	25	32	40	50
E mm	4	4	5,5	5	6	6
G mm	17,78	23,825	23,825	31,267	44,399	63,348
Concentricity deviation max. mm	0,01	0,01	0,01	0,01	0,01	0,015
Speed max. min ⁻¹	7000	6300	5000	3800	3000	2600
Workpiece weight max. kg	40	130	150	250	650	900
Weight without inserts	440	750	1100	1900	4400	8600
Weight g	900	1700	2200	3700	8000	-
Spare live spindle	009836	009838	009843	009870	009872	009874

Interchangeable inserts

A06
Interchangeable inserts 60°

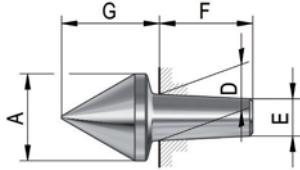

Item no.	Size	A mm	D mm	E mm	F mm	G mm
070725	102	16	7	5,2	18	20
070728	104	20	12	9,6	24	24
070731	106	24	12	9,6	24	27,5
070734	108	28	15	12	30	31,5
070737	110	38	22	18,5	35	43
070740	114	50	28	24	40	54

A06
Interchangeable inserts 90°

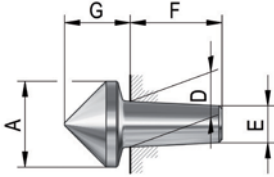

Item no.	Size	A mm	D mm	E mm	F mm	G mm
070727	102	16	7	5,2	18	14,5
070730	104	20	12	9,6	24	16,5
070733	106	24	12	9,6	24	19
070736	108	28	15	12	30	21,5
070739	110	38	22	18,5	35	29
070742	114	50	28	24	40	36

A06
Interchangeable inserts 60°VL

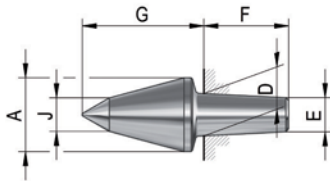

Item no.	Size	A mm	D mm	E mm	F mm	G mm	J mm
070719	102	14	7	5,2	18	25	6
070720	104; 106	18	12	9,6	24	30	8
070721	108	26	15	12	30	43	12
070722	110	32	22	18,5	35	55	13
070723	114	42	28	24	40	70	18,5

A06
Interchangeable inserts for tubular workpieces 60°

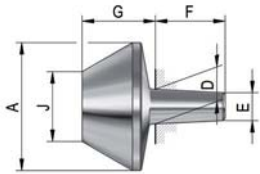

Item no.	Size	A mm	D mm	E mm	F mm	G mm	J mm
070700	102	25	7	5,2	18	21	10
070701	104	35	12	9,6	24	26	15
070702	106	45	12	9,6	24	27	25
070703	108	55	15	12	30	31,5	30
070704	110	70	22	18,5	35	39	40
070705	114	100	28	24	40	52	55

A06
Interchangeable inserts A for centreless workpieces 60°

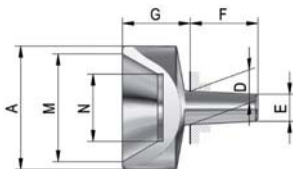

Item no.	Size	A mm	D mm	E mm	F mm	G mm	M mm	N mm
070707	102	25	7	5,2	18	18	20	10
070708	104	35	12	9,6	24	24	30	15
070709	106	45	12	9,6	24	25	40	25
070710	108	55	15	12	30	30	48	30
070711	110	70	22	18,5	35	39	63	40
070712	114	100	28	24	40	52	90	55

Interchangeable inserts

A06
Interchangeable inserts **B** for centreless workpieces 60°

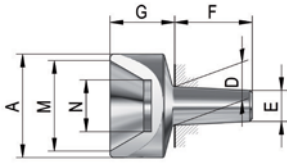

Item no.	Size	A mm	D mm	E mm	F mm	G mm	M mm	N mm
228620	102	16	7	5,2	18	12	12	6
228621	106	22	12	9,6	24	16	18	10
228622	108	40	15	12	30	25	35	20
308632	110	52	22	18,5	35	30	45	30

A06
Extractor



Item no.	For size
061707	102
061708	104/106/108
061709	110/114

A14
Mounting sleeve for clamping the face driver in the rotary chuck

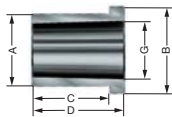

Item no.	MT inside	A mm	B mm	C mm	D mm	G mm
085033	3	32	39	32	40	23,825
085034	4	40	47	42	50	31,267
085035	5	55	62	52	60	44,399
085036	6	75	83	62	70	63,448

Live centres

Flex - interchangeable inserts

Live centres



APPLICATION

For counter-clamping workpieces on turning and grinding machines.

TYPE

With interchangeable inserts made of wear-resistant tool steel for maximum flexibility.

CUSTOMER BENEFITS

- ④ Wide range of applications thanks to interchangeable inserts
- ④ Quick change of interchangeable inserts

TECHNICAL FEATURES

- Body hardened and ground
- Inserts through-hardened and ground

Included in scope of delivery:

- 1 basic body for interchangeable inserts
- 1 extractor
- 1 insert 60°, 90°, 60°VL
- 1 insert or tubular workpieces 60°
- 2 inserts for centreless workpieces 60°
- Inclusive wooden case

A06

Complete with all inserts in a sturdy wooden case

Item no.	061702	061703	061704	061705	061706
Mount MT	2	3	3	4	5
Size	102	104	106	108	110
Workpiece weight max. kg	40	130	150	250	650
Weight g	900	1700	2200	3700	8000

REVOLVING CENTERING TAPER

For counter-clamping workpieces with large boreholes, (e.g. pipes) on turning and grinding machines, in one set-up. The centre point of the revolving centering taper from RÖHM is hardened and ground for maximum wear resistance.

REVOLVING CENTERING TAPER



- ⊕ Large clamping range for a wide range of boreholes and centres
- ⊕ Robust precision bearing for high axial and radial loads

REVOLVING CENTERING TAPER WITH INTERCHANGEABLE INSERTS



- ⊕ Maximum flexibility thanks to use of exchangeable centering taper attachments
- ⊕ Quick change of centering taper attachment in case of wear



APPLICATION

For counter-clamping workpieces with large boreholes, such as pipes on lathes and grinding machines.

TYPE

Revolving centering taper in pointed version or cone truncated version.

CUSTOMER BENEFITS

- ② Large clamping range for a wide range of boreholes and centres
- ② Proven 3-fold bearing for high axial and radial load

TECHNICAL FEATURES

- Body hardened and ground

A06
Revolving centering taper, **pointed**, as revolving centre for tubular workpieces as well as centre for machining standard workpieces

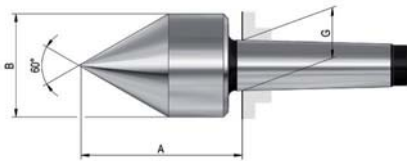

Item no.	Size	Mount MT	A mm	B mm	G	Workpiece weight max. kg	Concentricity deviation max. mm	Speed max. min ⁻¹	Weight g
010613	272	2	61	42	17,78	200	0,01	6000	400
010635	273	3	79	56	23,825	400	0,008	6000	1100
010638	274	4	100	64	31,267	800	0,008	4000	1600
010642	275	5	115,5	78	44,399	1600	0,008	4000	3600
306396	276	6	153	105	63,348	2500	0,008	2500	10000

A06
Revolving centering taper, **cone truncated, 60°**

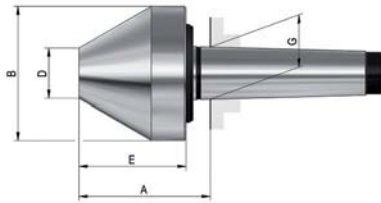

Item no.	Size	Mount MT	A mm	B mm	D mm	E mm	G	Workpiece weight max. kg	Concentricity deviation max. mm	Speed max. min ⁻¹	Weight g
301616	171a	2	65	50	20	52	17,78	200	0,008	6000	1200
301556	172	2	77	80	30	64	17,78	300	0,008	5000	2000
301557	172a	3	77	80	30	64	23,825	400	0,008	5000	2200
221605	173	3	96,5	120	30	83	23,825	600	0,008	4000	4200
301558	172b	4	78,5	80	30	64	31,267	400	0,008	5000	2300
044023	173a	4	98	120	30	83	31,267	800	0,008	4000	4500
090483	173b	5	99	120	30	83	44,399	800	0,008	4000	5300

A06
Revolving centering taper, **cone truncated, 75°**

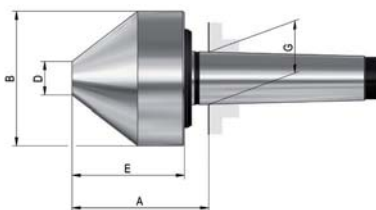

Item no.	Size	Mount MT	A mm	B mm	D mm	E mm	G	Workpiece weight max. kg	Concentricity deviation max. mm	Speed max. min ⁻¹	Weight g
301559	172	2	80	80	20	67	17,78	300	0,008	5000	2000
301560	172a	3	80	80	20	67	23,825	400	0,008	5000	2000
062211	173	3	85,5	120	30	72	23,825	600	0,008	4000	4200
301561	172b	4	81,5	80	20	67	31,267	400	0,008	5000	2400
062224	173a	4	87	120	30	72	31,267	800	0,008	4000	4300
062299	174	4	107	170	50	90	31,267	1200	0,01	2800	9700
062232	173b	5	88	120	30	72	44,399	800	0,008	4000	5100
063614	174a	5	106	170	50	90	44,399	1600	0,01	2800	10600
063662	175	5	146,5	250	75	130	44,399	2000	0,01	2200	34000
063633	174b	6	107,5	170	50	90	63,348	1600	0,01	2800	13300
063656	175a	6	148	250	75	130	63,348	2000	0,01	2200	37000
063680	176	6	184	350	120	168	63,348	4000	0,015	1200	82000



APPLICATION

For counter-clamping workpieces with large boreholes, such as pipes on lathes and grinding machines.

TYPE

With interchangeable centering taper attachments. Optionally with draw-off nut or fixed shaft.

CUSTOMER BENEFITS

- ⊕ High flexibility thanks to interchangeable centering taper attachments
- ⊕ Quick change of interchangeable centering taper attachments

TECHNICAL FEATURES

- Body hardened and ground
- Centering taper inserts hardened and ground

A06
Revolving centering taper

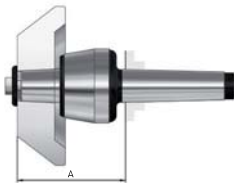

Item no.	Size	Mount MT	A mm	Workpiece weight max. kg	Concentricity deviation max. mm	Speed max. min ⁻¹	Weight g
304562	108	4	103	800	0,005	3800	2200
304563	110	5	128	1600	0,005	3000	4800
304564	114	6	159	3000	0,005	2600	12000

With fastening screw and disc, without centering taper attachment

A06
Revolving centering tapers **with draw-off nut**, for high load

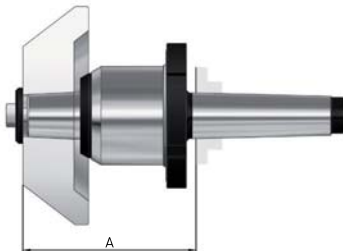

Item no.	Size	Mount MT	A mm	Workpiece weight max. kg	Concentricity deviation max. mm	Speed max. min ⁻¹	Weight g
304583	494	4	118	1000	0,005	7000	3200
304584	495	5	140	2000	0,005	6000	6500
304585	496	6	168	3500	0,005	4800	13500

With fastening screw and disc, without centering taper attachment

A07
Fixed shafts



Item no.	Mount MT	A mm	Workpiece weight max. kg	Concentricity deviation max. mm	Weight g
304580	4	45	2000	0,003	800
304581	5	60	4800	0,003	2000
304582	6	70	12000	0,003	5500

With fastening screw and disc, without centering taper attachment

A06

Suitable inserts AZ for centering tapers, standard version, taper 75°

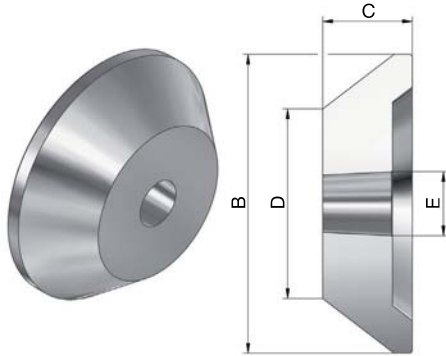

Item no.	Size	for MT	B mm	C mm	D mm	E mm	Weight g
304565 ¹⁾	1	4	60	68	5	32	900
304566	2	4	100	45	45	32	1500
304567	3	4	150	45	95	32	4100
304568	4	4	200	45	145	32	6000
304569	5	4	250	45	195	32	8500
304570	1	5	100	43	45	40	1500
304571	2	5	150	43	95	40	4400
304572	3	5	200	43	145	40	6100
304573	4	5	250	43	195	40	8100
304574	5	5	300	43	245	40	11600
304575	1	6	150	54	95	50	3000
304576	2	6	200	54	145	50	8100
304577	3	6	250	54	195	50	11100
304578	4	6	300	54	245	50	14000
304579	5	6	350	54	295	50	18800

¹⁾ without fixing by screw and washer

DEAD CENTRES

Optimally suited for the counter-clamping of workpieces on turning machines with tailstock bearing and grinding machines in one set-up as well as for measurement technology. The dead centres are hardened and ground.

ADVANTAGES AT A GLANCE

- ⊕ High wear resistance thanks to tool steel / carbide insert
- ⊕ High load capacity and rigidity thanks to compact design
- ⊕ Concentricity deviation of up to 0.005 mm

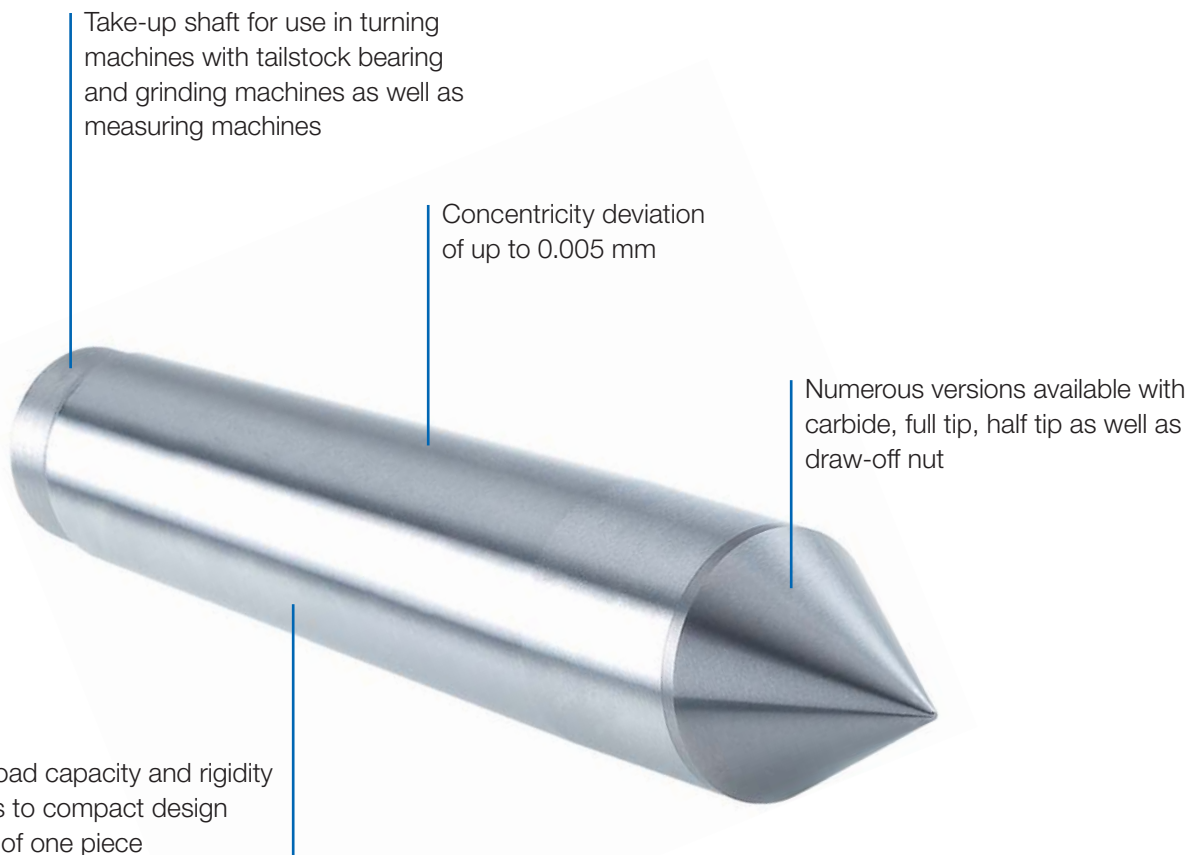



APPLICATION

For counter-clamping workpieces on lathes with tailstock bearing and grinding machines.

TYPE

Designs with concentricity of 0.003 mm or higher are available on request.

CUSTOMER BENEFITS

- ⊕ High wear resistance thanks to tool steel / carbide insert
- ⊕ High load capacity and rigidity since tips are one piece

TECHNICAL FEATURES

- Dead centres are hardened and ground

A07
DIN 806, full point, ground, with full carbide tip

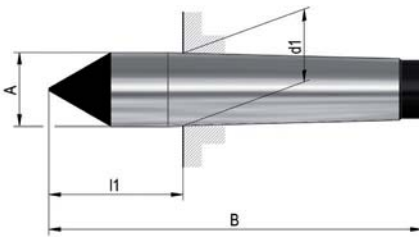

Item no.	Mount MT	A mm	B mm	d1 mm	l1 mm	Weight g
326786	2	18	100	17,78	36	175
306402	3	24,1	125	23,825	44	400
221398	4	31,6	160	31,267	57,5	855
326816	5	44,7	200	44,399	70,5	2160

A07
DIN 806, full point, ground, with carbide insert and regrinding line

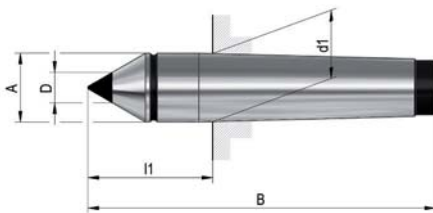

Item no.	Mount MT	A mm	B mm	D mm	d1 mm	l1 mm	Weight g
017171	2	18	100	7	17,78	36	155
017172	3	24,1	125	11	23,825	44	360
017173	4	31,6	160	14	31,267	57,5	770
017174	5	44,7	200	18	44,399	70,5	1950

A07
DIN 806, full point, material: Mat.

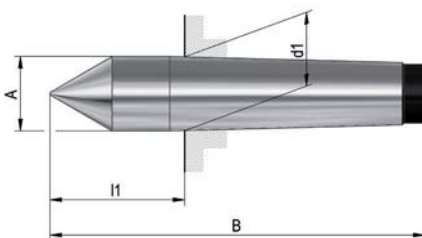

Item no.	Mount MT	A mm	B mm	d1 mm	l1 mm	Weight g
013706	0	9,2	70	9,045	20	30
013707	1	12,2	80	12,065	26,5	60
013709	2	18	100	17,78	36	150
013711	3	24,1	125	23,825	44	340
013712	4	31,6	160	31,267	57,5	760
013715	5	44,7	200	44,399	70,5	1920
013718	6	63,8	270	63,348	88	5200

FZS

A07
Similar **DIN 807, full point**, with draw-off nut and SW, material: Mat.

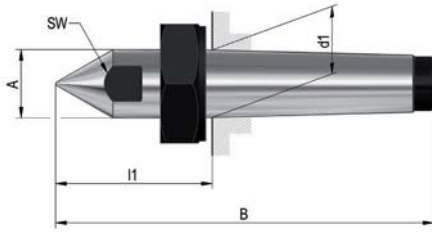

Item no.	Mount MT	A mm	B mm	C	d1 mm	l1 mm	Key-width SW	Weight g
005654	3	24,1	138	M27x1,5	23,825	57	19	580
005357	4	31,6	175	M36x1,5	31,267	72,5	27	800
005381	5	44,7	217	M48x1,5	44,399	87,5	36	2900
005426	6	63,8	290	M68x1,5	63,348	108	55	7200

A07
Similar **DIN 807, full point**, with draw-off nut and SW, with extended centre point, material: Mat.

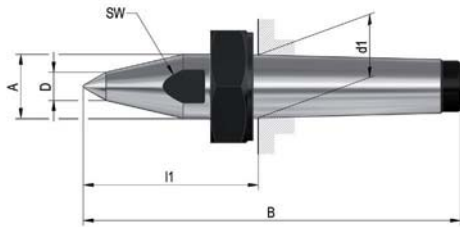

Item no.	Mount MT	A mm	B mm	C	D mm	d1 mm	l1 mm	Key-width SW	Weight g
249576	3	24,1	148	M27x1,5	10	23,825	67	19	600
249577	4	31,6	186,5	M36x1,5	14	31,267	84	27	1285
249578	5	44,7	242	M48x1,5	16	44,399	112	36	3000
249579	6	63,8	330	M68x1,5	20	63,348	148	55	7900

A07
Draw-off nut



Item no.	C	H mm	Key-width SW	Weight g
005656	M27x1,5	17,5	41	110
005359	M36x1,5	21	55	240
005383	M48x1,5	23	75	480
005428	M68x1,5	25,5	100	900

A07
DIN 806, half point, ground, with carbide insert

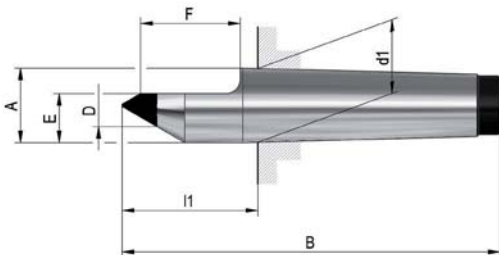

Item no.	Mount MT	A mm	B mm	D mm	E mm	F mm	d1 mm	l1 mm	Weight g
027439	2	18	100	7	11	30	17,78	36	150
027440	3	24,1	125	11	15	38	23,825	44	335
026571	4	31,6	160	14	21	50	31,267	57,5	750
027441	5	44,7	200	18	29,4	63	44,399	70,5	1830

A07
DIN 806, half point, material: Mat.

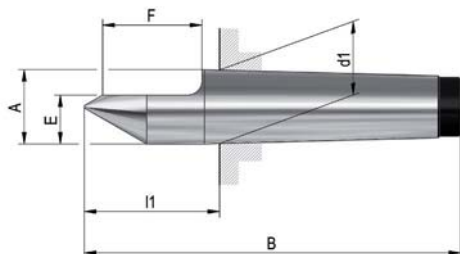

Item no.	Mount MT	A mm	B mm	E mm	F mm	d1 mm	l1 mm	Weight g
013868	2	18	100	11	30	17,78	36	145
013870	3	24,1	125	15	38	23,825	44	310
013871	4	31,6	160	21	50	31,267	57,5	710
013997	5	44,7	200	29,4	63	44,399	70,5	1925



TURNING AND MILLING IN ONE SET-UP

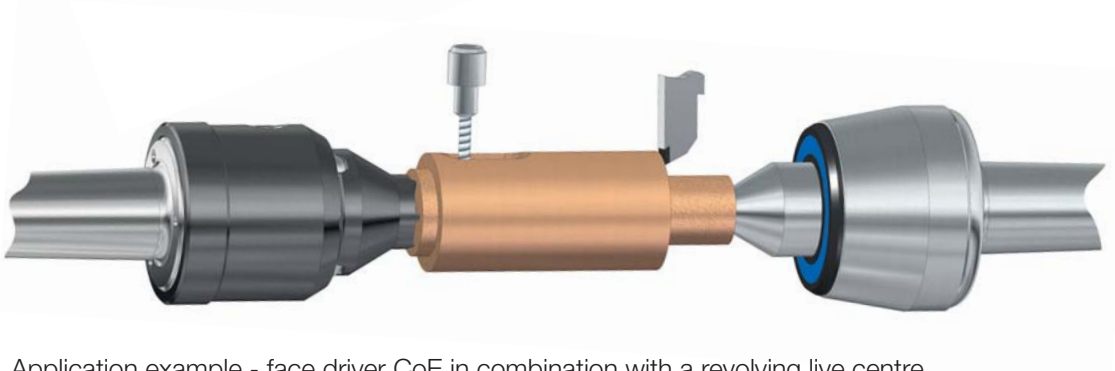

Application example - face driver CoE in combination with a revolving live centre.
Turning and milling workpieces in one set-up.



Video CoE

CONSTANT FACE DRIVERS

The Constant face drivers of RÖHM are optimally suited for the rational turning and milling of workpieces over their entire length. All Constant face drivers are developed according to the modular principle, so that a universal exchange of a large multitude of driver discs and centre points is possible.

ADVANTAGES AT A GLANCE

- ⊕ Maximum flexibility thanks to the modular principle
- ⊕ High concentricity thanks to narrow tolerances
- ⊕ Constant clamping force thanks to mechanical or hydraulic pressure compensation, even for uneven workpiece faces

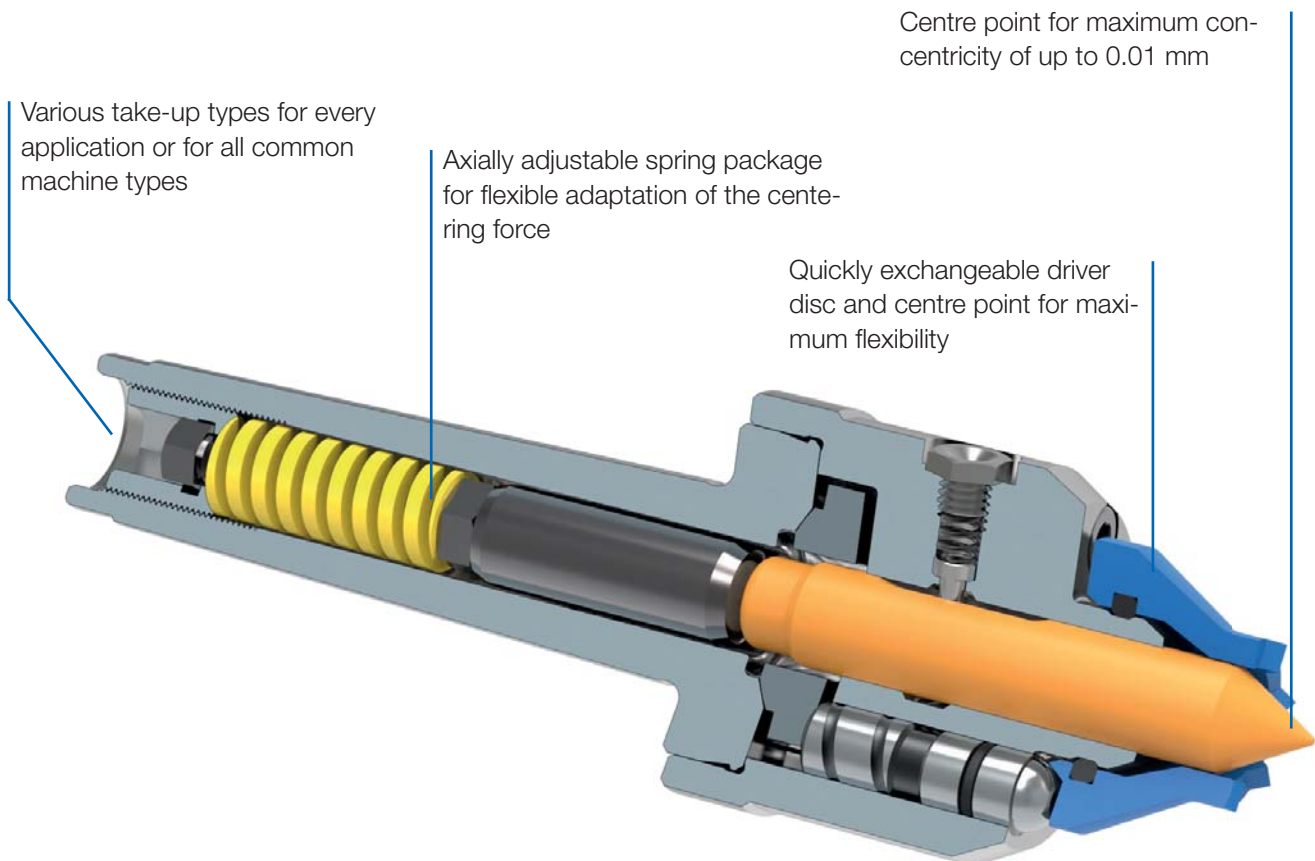

Operation guide



TYPE	CoE	CoA	CoK
Machining	Turning and milling in one set-up Patented compensating driving disc, radially backlash-free	Turning	Turning For machining workpieces which are highly unbalanced, very heavy, for high chip removal or for irregular cutting
Concentricity deviation max.	up to 0.01 mm	up to 0.015 mm	up to 0.01 mm
Actuation	not power-operated	not power-operated	power-operated
Pressure compensation	mechanical	mechanical / hydraulic	mechanical
Workpiece weight	up to 100 kg	up to 100 kg	up to 350 kg
Centre point	resilient	resilient	fixed
Clamping-Ø	8 - 80 mm	8 - 80 mm	8 - 80 mm
Adapter	with morse taper / with cylindrical shank	with morse taper / with morse taper and draw-off nut / with cylindrical shank for clamping in lathe chucks / with short taper / in flange type	with centring mount for adapter plate
Page	2040	2043	2052

Clamping power diagramm

Clamping power diagramm

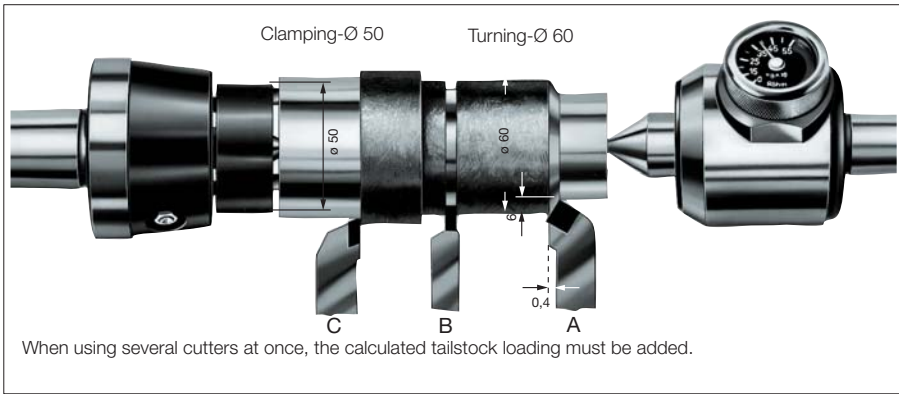

Example

A Turning against the headstock

1. Cutting capacity: $6 \times 0,4 = 2,4 \text{ mm}^2$
2. Workpiece strength: $= 63 \text{ daN/mm}^2$
3. Clamping ratio: $60 : 50 = 1,2$
4. Tailstock loading from graph: $F_{\text{Tailstock}} = 450 \text{ daN}$

* Conversation factor for:

B Radial grooving $F_{\text{Tailstock}} \times 1,5$

C Turning against tailstock $F_{\text{Tailstock}} \times 2$

When using several cutters at once, the calculated tailstock loading must be added.

Workpiece strength daN/mm ²	40	50	63	80	100	125
Material	St 34-37	St 42	St 50	St 60-70	20 MnCr 5	18CrNi 8
	9-15 S 20	C 10	C 15-22	C 35-45	C 60	30 CrMoV 9
	GG 14-35	GG 40	22 S 20	16 MnCr 5	15 CrNi 6	50 CrMo 4
	GGG-38	GGG-42	GGG-50	GGG-60	GGG-80	105 WCr 6

The RÖHM slide rule, Item No. 88231 may also be used for easy calculation of the axial clamping power.

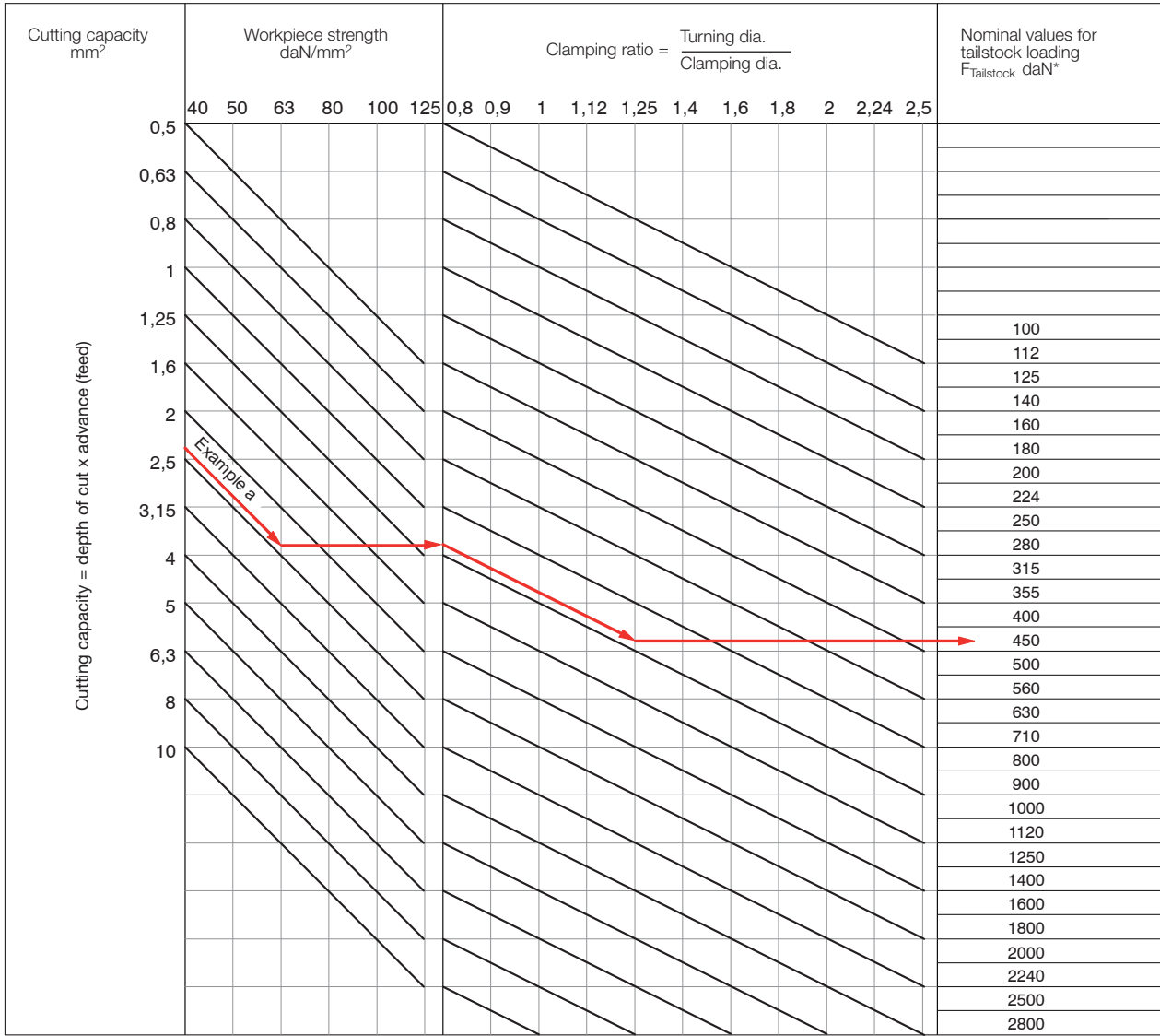

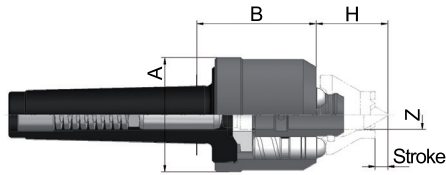

APPLICATION

For the rational **turning and milling** of workpieces on its entire length without reclamping with max. precision.

TYPE

Basic body with morse taper and mechanical pressure compensation.
Clamping circuit \varnothing 8-80 mm.
Workpiece weight max. 100 kg.

CUSTOMER BENEFITS

- ③ For **turning and milling** in one set-up
- ③ Compensating driving disc, radially backlash-free
- ③ Maximum concentricity of up to 0.01 mm
- ③ Stable and constant workpiece length stop on the front side thanks to resilient centre point
- ③ Maximum flexibility thanks to universal exchange of driving disc and centre point

TECHNICAL FEATURES

- Guide value for axially permissible total load on 3 support pistons: 9000 N

A14

Basic body with morse taper (all basic bodies without driving disc and centre) **mechanical**

Item no.	MT	A mm	B mm	H mm	Z mm	Stroke Centre mm	Weight approx. g
310065	3	62	65	max. 38 min. 26	16	10	1800
310066	4	62	65	max. 38 min. 26	16	10	1900
310068	5	62	65	max. 38 min. 26	16	10	2000

Other take-ups available on request

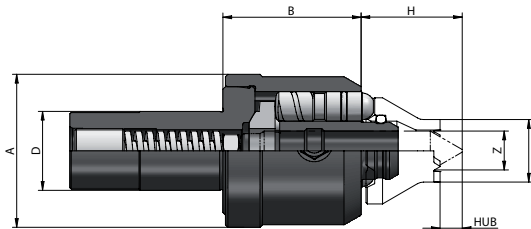

APPLICATION

For the rational **turning and milling** of workpieces on its entire length without reclamping with max. precision.

TYPE

Basic body with cylindrical shank and mechanical pressure compensation.
Clamping circuit \varnothing 8-80 mm.
Workpiece weight max. 100 kg.

CUSTOMER BENEFITS

- ③ For **turning and milling** in one set-up
- ③ Compensating driving disc, radially backlash-free
- ③ Maximum concentricity of up to 0.01 mm
- ③ Stable and constant workpiece length stop on the front side thanks to resilient centre point
- ③ Maximum flexibility thanks to universal exchange of driving disc and centre point

TECHNICAL FEATURES

- Guide value for axially permissible total load on 3 support pistons: 9000 N

A14

Basic body with cylindrical shank (all basic bodies without driving disc and centre) **mechanical**

Item no.	Centre \varnothing mm	A mm	B mm	H mm	Z mm	Stroke Centre mm	Weight approx. g
310071	25	62	56	max.38 min.26	16	10	1900
310072	32	62	56	max.38 min.27	16	10	2000

Other take-ups available on request

Accessories CoE

A14

Driving discs, toothed, right- and left-hand rotation, free from play

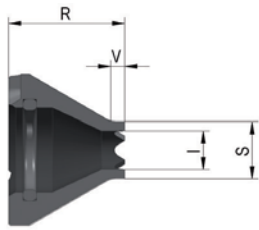

Item no.	Clamping circuit Ø S mm	Approx. turning range	l mm	R mm	V mm	Assoc. centre point Ø Y mm	Axial load max. N
1209000	8	9-16	4,5	38	4	4	4000
1209001	10	11-20	4,5	38	4	4	6000
1209002	12	13-24	7	36	4	6	6000
1209003	16	17-32	11	33	4	10	6000
1209004	20	21-40	13	30	4	12	8000
1209005	25	26-50	17	30	8	16	9000
1209006	32	33-64	22	30	10	16	9000

Driving discs with carbide tothing on request

A14

Driving discs, with interchangeable carbide driving plates 6 x 3,2, right- and left-hand rotation, free from play

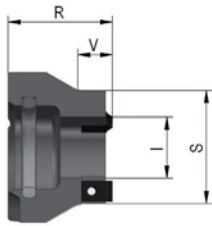

Item no.	Clamping circuit Ø S mm	Approx. turning range	l mm	R mm	V mm	Assoc. centre point Ø Y mm	Axial load max. N
1209007	20	21-40	7	30	8	6	9000
1209008	25	26-50	11	30	8	10	9000
1209009	32	33-64	17,5	30	10	16	9000
1209010	40	41-80	27	30	16	16	9000

A14

Driving discs, with interchangeable carbide driving plates 6 x 3,2, which can be used on 4 sides, right- and left-hand rotation, free from play

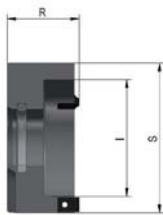

Item no.	Clamping circuit Ø S mm	Approx. turning range	l mm	R mm	Assoc. centre point Ø Y mm	Axial load max. N
1209011	50	51-100	36	30	16	9000
1209012	63	64-126	49	30	16	9000
1209013	80	81-160	66	30	16	9000

A14

Centres

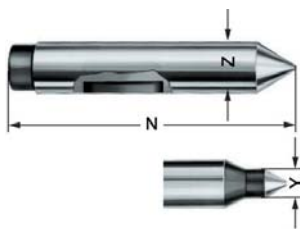

Item no.	Clamping circuit Ø S mm	N mm	Y mm	Z mm
1209016	8-10	90	4	16
1209017	12	90	6	16
1209018	16	90	10	16
1209019	20	90	12	16
1209020	25-80	90	16	16

Centering taper on request

A14

Carbide driving plates, right- and left-hand rotation



Item no.	Size	Clamping circuit Ø mm
088970	6x3,2	20-32

Accessories CoE

A14

Mounting sleeve, for clamping the face driver in the lathe chuck

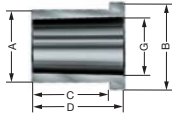

Item no.	MT inside	A mm	B mm	C mm	D mm	G mm
085033	3	32	39	32	40	23,825
085034	4	40	47	42	50	31,267
085035	5	55	62	52	60	44,399

Face driver accessories CoE

CoE - product ranges

A14

CoE-small assortment in wooden box, mechanical pressure compensation, clamping circuit \varnothing 12-50, turning range 13-100 mm

Included in delivery: 1x basic body, 4x driving discs (clamping circuit \varnothing 12, 20, 32, 50), 3x centre points (centering \varnothing 6, 12, 16)



Item no.	MT	Weight approx. g
1209048	3	3600
1209049	4	3870
1209050	5	4550

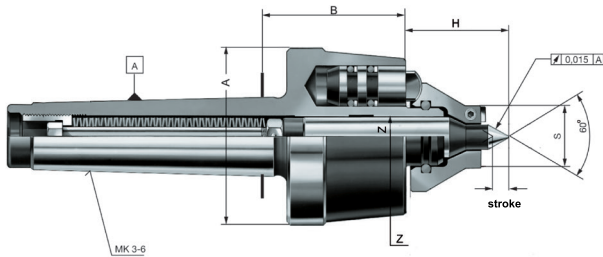

APPLICATION

For the rational turning of workpieces on its entire length without reclamping with max. precision.

TYPE

Basic body with morse taper and hydraulic pressure compensation.
Clamping circuit Ø 8-80 mm.
Workpiece weight max. 100 kg.

CUSTOMER BENEFITS

- ⊕ Constant clamping force thanks to hydraulic pressure compensation, even for uneven workpiece faces
- ⊕ Stable and constant workpiece length stop on the front side thanks to resilient centre point
- ⊕ Maximum concentricity of up to 0.015 mm
- ⊕ Maximum flexibility thanks to universal exchange of driving disc and centre point

TECHNICAL FEATURES

- Guide value for axially permissible total load on 3 support pistons: 20.000 N

A14

Basic body with morse taper (basic body without driving disc and centre), **hydraulic**

Item no.	MT	A mm	B mm	H mm	Z mm	Stroke Centre mm	Weight approx. g
088173	3	70	54	max. 45 min. 26	16	10	1600
088174	4	70	56,5	max. 45 min. 26	16	15	1800
088175	5	70	56,5	max. 45 min. 26	16	15	2800
088176	6	70	56,5	max. 45 min. 26	16	15	4400

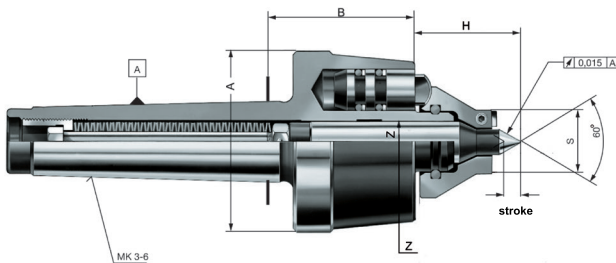

APPLICATION

For the rational turning of workpieces on its entire length without reclamping with max. precision.

TYPE

Basic body with morse taper and hydraulic pressure compensation.
Clamping circuit Ø 8-80 mm.
Workpiece weight max. 100 kg.

CUSTOMER BENEFITS

- ⊕ Constant clamping force thanks to hydraulic pressure compensation, even for uneven workpiece faces
- ⊕ Stable and constant workpiece length stop on the front side thanks to resilient centre point
- ⊕ Maximum concentricity of up to 0.015 mm
- ⊕ Maximum flexibility thanks to universal exchange of driving disc and centre point

TECHNICAL FEATURES

- Guide value for axially permissible total load on 3 support pistons: 20.000 N

A14

Basic body with morse taper, with draw-off nut (basic body without driving disc and centre), **hydraulic**

Item no.	MT	A mm	B mm	H mm	Z mm	Stroke Centre mm	Weight approx. g
088177	3	82	54	max. 45 min. 26	16	10	1800
088178	4	82	56,5	max. 45 min. 26	16	15	2200
088179	5	82	56,5	max. 45 min. 26	16	15	3000
088180	6	82	56,5	max. 45 min. 26	16	15	4600

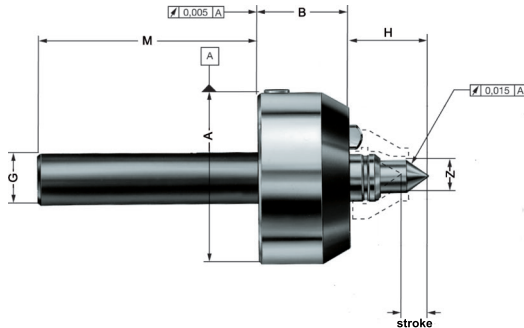

APPLICATION

For the rational turning of workpieces on its entire length without reclamping with max. precision.

TYPE

Basic body with cylindrical shank and hydraulic pressure compensation. Clamping circuit \varnothing 8-80 mm. Workpiece weight max. 100 kg.

CUSTOMER BENEFITS

- ③ Constant clamping force thanks to hydraulic pressure compensation, even for uneven workpiece faces
- ③ Stable and constant workpiece length stop on the front side thanks to resilient centre point
- ③ Maximum concentricity of up to 0.015 mm
- ③ Maximum flexibility thanks to universal exchange of driving disc and centre point

TECHNICAL FEATURES

- Guide value for axially permissible total load on 3 support pistons: 20.000 N

A14
Basic body with **cylindrical shank** for clamping in lathe chucks, with **spring package** (basic body without driving disc and centre) **mechanical / hydraulic**

Item no.	A mm	B mm	G mm	H mm	M mm	Z mm	Stroke Centre mm	Weight approx. g
088074 ¹⁾	85	45	25	max. 45 min. 26	110	16	15	2300
313085 ²⁾	85	45	25	max. 45 min. 26	110	16	15	2300

¹⁾ with hydraulic compensation
²⁾ with mechanical compensation

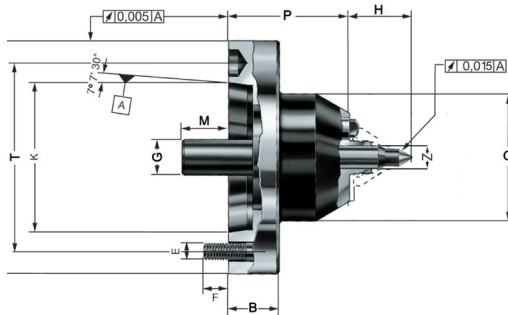

APPLICATION

For the rational turning of workpieces on its entire length without reclamping with max. precision.

TYPE

Basic body with short taper and mechanical pressure compensation. Clamping circuit \varnothing 8-80 mm. Workpiece weight max. 100 kg.

CUSTOMER BENEFITS

- ③ Constant clamping force thanks to mechanical pressure compensation, even for uneven workpiece faces
- ③ Stable and constant workpiece length stop on the front side thanks to resilient centre point
- ③ Maximum concentricity of up to 0.015 mm
- ③ Maximum flexibility thanks to universal exchange of driving disc and centre point

TECHNICAL FEATURES

- Guide value for axially permissible total load on 3 support pistons: 20.000 N

A14
Basic body with **short taper ISO 702-1** (DIN 55026), with **spring package** (basic body without driving disc and centre) **mechanical**

Item no.	Short-taper	A mm	B mm	E	F mm	G mm	H mm	K mm	M mm	O mm	P mm	T mm	Z mm	Stroke Centre mm	Weight approx. g
313905	5	133	-	M 10	15	25	max. 45 min. 26	82,563	32	90	86	104,8	16	11	6500
313906	6	165	35	M 12	18	25	max. 45 min. 26	106,375	32	90	86	133,4	16	11	7000
313907	8	210	40	M 16	23	25	max. 45 min. 26	139,719	32	90	86	171,4	16	11	8100

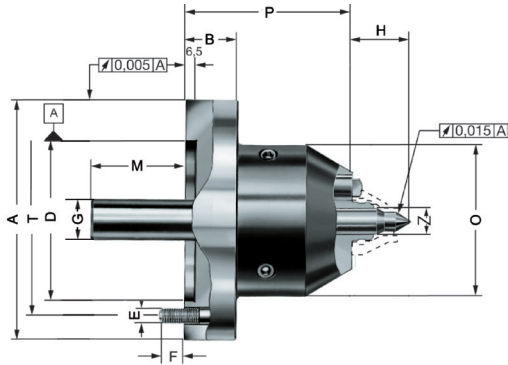

APPLICATION

For the rational turning of workpieces on its entire length without reclamping with max. precision.

TYPE

Basic body with centring mount and hydraulic / mechanical pressure compensation.
Clamping circuit \varnothing 8-80 mm.
Workpiece weight max. 100 kg.

CUSTOMER BENEFITS

- ⊕ Constant clamping force thanks to hydraulic / mechanical pressure compensation, even for uneven workpiece faces
- ⊕ Stable and constant workpiece length stop on the front side thanks to resilient centre point
- ⊕ Maximum concentricity of up to 0.015 mm
- ⊕ Maximum flexibility thanks to universal exchange of driving disc and centre point

TECHNICAL FEATURES

- Guide value for axially permissible total load on 3 support pistons: 20.000 N

A14

Basic body flange type, with spring set (basic body without driving disc and centre) mechanical / hydraulic

Item no.	A mm	B mm	D mm	E	F mm	G mm	H mm	M mm	O mm	P mm	T mm	Z mm	Stroke Centre mm	Weight approx. g
088046 ¹⁾	142	30	100	M 10	15	25	max. 45 min. 26	61	90	98	120	16	15	7300
313910 ²⁾	142	30	100	M 10	15	25	max. 45 min. 26	61	90	98	120	16	15	7300

¹⁾ with hydraulic compensation

²⁾ with mechanical compensation

Adapter plate CoA

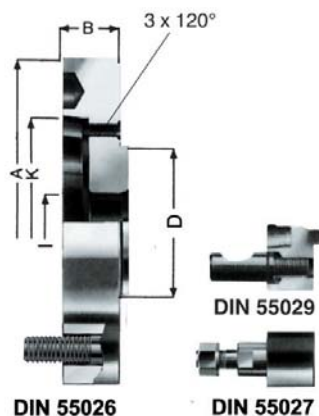

A14
Adapter plate **short taper**

Item no.	Design	Taper	A mm	B mm	D mm	l mm	K mm	Weight approx. g
088485	ISO 702-1	5	140	30	100	38	82,563	3100
088486	ISO 702-1	6	167	35	100	38	106,39	4800
088487	ISO 702-1	8	216	40	100	38	139,735	8700
088488	ISO 702-1	11	280	45	100	38	196,885	17000
088480	ISO 702-3	5	140	30	100	38	82,563	3100
088481	ISO 702-3	6	167	35	100	38	106,39	4800
088482	ISO 702-3	8	216	40	100	38	139,735	8700
088483	ISO 702-3	11	280	45	100	38	196,885	17000
088495	ISO 702-2	5	140	30	100	38	82,563	3100
088496	ISO 702-2	6	167	35	100	38	106,39	4800
088497	ISO 702-2	8	216	40	100	38	139,735	8700
088498	ISO 702-2	11	280	45	100	38	196,885	17000

Accessories CoA

A14

Driving discs, with interchangeable carbide driving plates 6 x 3.2, right- and left-hand rotation

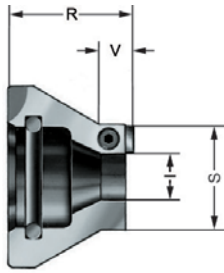

Item no.	Clamping circuit Ø S mm	Approx. turning range	l mm	R mm	V mm	Assoc. centre point Ø Y mm	Axial load max. N
088545	20 H	21-40	7	30	5	6	8000
088546	25 H	26-50	11	30	8	10	8000
088547	32 H	33-64	17,5	30	10	16	8000

A14

Driving discs, with interchangeable carbide driving plates 6 x 3.2, right-hand rotation

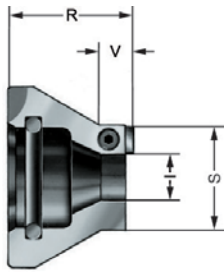

Item no.	Clamping circuit Ø S mm	Approx. turning range	l mm	R mm	V mm	Assoc. centre point Ø Y mm	Axial load max. N
089065	20 H	21-40	7	30	5	6	8000
089066	25 H	26-50	11	30	8	10	8000
089067	32 H	33-64	17,5	30	10	16	8000

A14

Driving discs, with interchangeable carbide driving plates 6 x 3.2, left-hand rotation

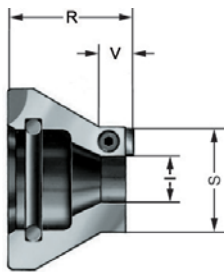

Item no.	Clamping circuit Ø S mm	Approx. turning range	l mm	R mm	V mm	Assoc. centre point Ø Y mm	Axial load max. N
089085	20 H	21-40	7	30	5	6	8000
089086	25 H	26-50	11	30	8	10	8000
089087	32 H	33-64	17,5	30	10	16	8000

A14

Driving discs, toothed, right- and left-hand rotation

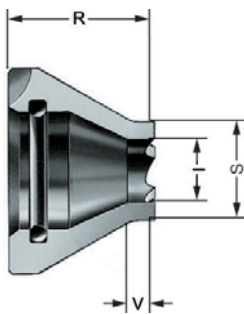

Item no.	Clamping circuit Ø S mm	Approx. turning range	l mm	R mm	V mm	Assoc. centre point Ø Y mm	Axial load max. N
088541	8	9-16	4,5	38	4	4	4000
088542	10	11-20	4,5	38	4	4	6000
088543	12	13-24	7	36	4	6	6000
088544	16	17-32	11	33	4	10	6000

Driving discs with carbide tothing on request

Accessories CoA

A14

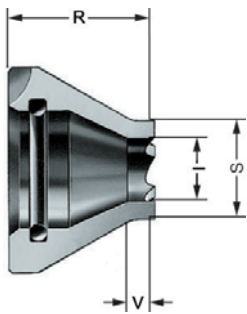
Driving discs, toothed, right-hand rotation

Item no.	Clamping circuit Ø S mm	Approx. turning range	l mm	R mm	V mm	Assoc. centre point Ø Y mm	Axial load max. N
088061	8	9-16	4,5	38	4	4	4000
088062	10	11-20	4,5	38	4	4	6000
088063	12	13-24	7	36	4	6	6000
088064	16	17-32	11	33	4	10	6000
088065	20	21-40	13	30	4	12	8000
088066	25	26-50	17	30	8	16	10000
088067	32	33-64	22	30	10	16	12500

Driving discs with carbide tothing, friction lining or diamond grain on request

A14

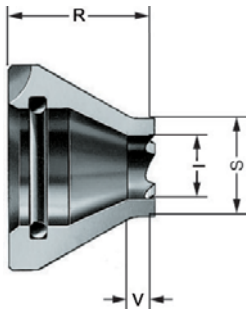
Driving discs, toothed, left-hand rotation

Item no.	Clamping circuit Ø S mm	Approx. turning range	l mm	R mm	V mm	Assoc. centre point Ø Y mm	Axial load max. N
088081	8	9-16	4,5	38	4	4	4000
088082	10	11-20	4,5	38	4	4	6000
088083	12	13-24	7	36	4	6	6000
088084	16	17-32	11	33	4	10	6000
088085	20	21-40	13	30	4	12	8000
088086	25	26-50	17	30	8	16	10000
088087	32	33-64	22	30	10	16	12500

Driving discs with carbide tothing on request

A14

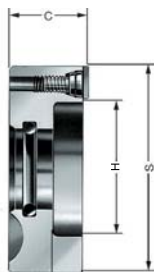
Driving discs, with interchangeable carbide driving plates 6 x 3,2, right- and left-hand rotation

Item no.	Clamping circuit Ø S mm	Approx. turning range	H mm	C mm	Assoc. centre point Ø Y mm	Axial load max. N
088548	40	41-80	20	24	16	14000
088549	50	51-100	28	24	16	14000
088550	63	64-126	41	24	16	14000
088551	80	81-160	58	24	16	14000

A14

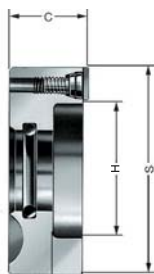
Driving discs, with interchangeable carbide driving plates 6 x 3,2, right-hand rotation

Item no.	Clamping circuit Ø S mm	Approx. turning range	H mm	C mm	Assoc. centre point Ø Y mm	Axial load max. N
088068	40	41-80	20	24	16	14000
088069	50	51-100	28	24	16	14000
088070	63	64-126	41	24	16	14000
088071	80	81-160	58	24	16	14000

Accessories CoA

A14

Driving discs, with interchangeable carbide driving plates 6 x 3,2, **left-hand rotation**

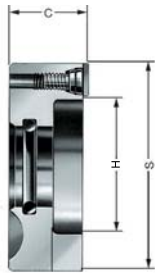

Item no.	Clamping circuit Ø S mm	Approx. turning range	H mm	C mm	Assoc. centre point Ø Y mm	Axial load max. N
088088	40	41-80	20	24	16	14000
088089	50	51-100	28	24	16	14000
088090	63	64-126	41	24	16	14000
088091	80	81-160	58	24	16	14000

A14

Centres CoA

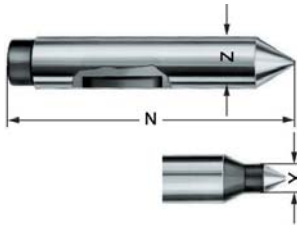

Item no.	Clamping circuit Ø S mm	N mm	Y mm	Z mm
088351	8-10	90	4	16
088352	12	90	6	16
088353	16	90	10	16
088354	20	90	12	16
088355	25-80	90	16	16
086758	25-80	110	16	16

A14

Centres CoA

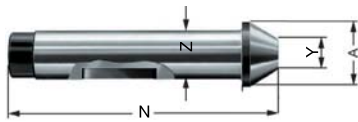

Item no.	Taper Ø		N mm	Z mm	Weight approx. g
	A mm	Y mm			
086619	21	10	90	16	136
086620	27	16	90	16	153
688878	34	23	90	16	190
086621	40	29	90	16	210
688880	48	37	90	16	250
086622	56	45	90	16	312

A14

Carbide driving plates, right- and left-hand rotation



Item no.	Size	Clamping circuit Ø mm
088970	6x3,2	20-32
087931	9,5x3,2	40-80

A14

Carbide driving plates, right- or left-hand rotation



Item no.	Size	Clamping circuit Ø mm
088810	6x3,2	20-32
088209	9,5x3,2	40-80

A14

Mounting sleeve, for clamping the face driver in the rotary chuck

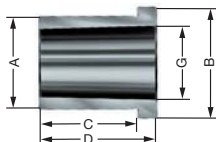

Item no.	MT inside	A mm	B mm	C mm	D mm	G mm
085033	3	32	39	32	40	23,825
085034	4	40	47	42	50	31,267
085035	5	55	62	52	60	44,399
085036	6	75	83	62	70	63,448

Accessories CoA

Accessories face drivers CoA

C15
Threaded pin



Item no.	Size	Clamping circuit Ø mm
234695	M 4 x 6	20
048205	M 5 x 8	25+32
088205	M 5 x 8	40-80

C15
O-ring



Item no.	Size
006252	21,82x3,53

A14
RÖHM slide rule for determining the axial tailstock force

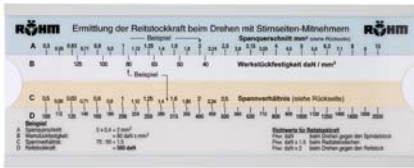

Item no.
088230

CoA - product ranges

A14

Basic equipment in a carton, hydraulic pressure compensation, clamping dia. 12 + 32 mm, turning range 13-64 mm



Item no.	MT	right-hand rotation	left-hand rotation	With draw-off nut	Weight approx. g
088553	3	●			2100
088557	3	●		●	2400
088573	3		●		2100
088577	3		●	●	2400
088554	4	●			2400
088558	4	●		●	2700
088574	4		●		2400
088578	4		●	●	2700
088555	5	●			3300
088559	5	●		●	3600
088575	5		●		3300
088579	5		●	●	3600
088556	6	●			4900
088560	6	●		●	5200
088576	6		●		4900
088580	6		●	●	5200

A14

Small assortment in wooden box, hydraulic pressure compensation, clamping dia. 12-50 mm, turning range 13-100 mm



Item no.	MT	right-hand rotation	left-hand rotation	With draw-off nut	Weight approx. g
088501	3	●			3900
088511	3	●		●	4200
088521	3		●		3900
088531	3		●	●	4200
088502	4	●			4300
088512	4	●		●	4600
088522	4		●		4300
088532	4		●	●	4600
088503	5	●			4900
088513	5	●		●	5200
088523	5		●		4900
088533	5		●	●	5200
088504	6	●			6600
088514	6	●		●	6800
088524	6		●		6600
088534	6		●	●	6800

Delivery includes:

- Basic body
- Driving discs clamping circuit (S) 12 / 20 / 32 / 50
- Centres-Ø (Y) 6 / 12

A14

Large assortment in wooden box, hydraulic pressure compensation, clamping dia. 10-80 mm, turning range 11-160 mm



Item no.	MT	right-hand rotation	left-hand rotation	With draw-off nut	Weight approx. g
088218	3	●			5600
088223	3		●		5600
088233	3	●		●	5900
088238	3		●	●	5900
088219	4	●			6000
088224	4		●		6000
088234	4	●		●	6300
088239	4		●	●	6300
088220	5	●			6600
088225	5		●		6600
088235	5	●		●	6900
088240	5		●	●	6900
088221	6	●			8300
088226	6		●		8300
088236	6	●		●	8500
088241	6		●	●	8500

Delivery includes:

- Basic body
- Driving discs clamping circuit (S) 10 / 12 / 16 / 20 / 25 / 32 / 40 / 50 / 63 / 80
- Centres-Ø (Y) 4 / 6 / 10 / 12 / 16

CoK 8-80 mm

Power-operated face drivers CoK

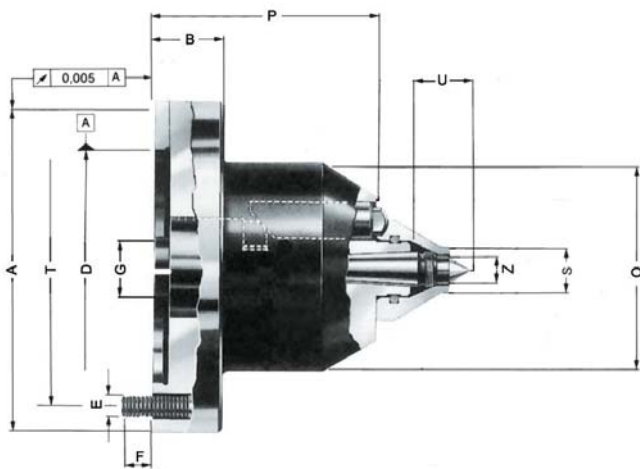

APPLICATION

For machining workpieces with high unbalance, heavy weight, high chip removal or irregular cutting.

TYPE

Force-actuated face driver with mechanical pressure compensation.
Clamping circuit Ø 8-80 mm.
Workpiece weight max. 350 kg.

CUSTOMER BENEFITS

- ⊕ Maximum concentricity of up to 0.01 mm
- ⊕ Workpiece longitudinal stop realized in centering
- ⊕ Low centering force, even at max. cutting load
- ⊕ Maximum flexibility thanks to universal exchange of driving disc and centre point

TECHNICAL FEATURES

- The drivers are pressed against the workpiece with force-actuation

C15

Basic body (without centre, without draw-off nut) **mechanical**

Item no.	A mm	B mm	D mm	E	F mm	G mm	O mm	P mm	T mm	Z mm	Driving disc stroke mm	Weight approx. g
313900	142	30	100	M 10	15	25	90	93	120	15	5	6500

Draw-off nut M 14x1.5 Id.No. 089229

Adapter plate CoK



A14

Adapter plate short taper

Item no.	Design	Taper	A mm	B mm	D mm	l mm	K mm	Weight approx. g
088485	ISO 702-1	5	140	30	100	38	82,563	3100
088486	ISO 702-1	6	167	35	100	38	106,39	4800
088487	ISO 702-1	8	216	40	100	38	139,735	8700
088488	ISO 702-1	11	280	45	100	38	196,885	17000
088480	ISO 702-3	5	140	30	100	38	82,563	3100
088481	ISO 702-3	6	167	35	100	38	106,39	4800
088482	ISO 702-3	8	216	40	100	38	139,735	8700
088483	ISO 702-3	11	280	45	100	38	196,885	17000
088495	ISO 702-2	5	140	30	100	38	82,563	3100
088496	ISO 702-2	6	167	35	100	38	106,39	4800
088497	ISO 702-2	8	216	40	100	38	139,735	8700
088498	ISO 702-2	11	280	45	100	38	196,885	17000

Accessories CoK

A14

Driving discs, toothed, right-hand rotation

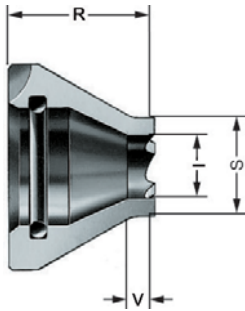

Item no.	Clamping circuit Ø S mm	Approx. turning range	l mm	R mm	V mm	Assoc. centre point Ø Y mm	Axial load max. N
088061	8	9-16	4,5	38	4	4	4000
088062	10	11-20	4,5	38	4	4	6000
088063	12	13-24	7	36	4	6	6000
088064	16	17-32	11	33	4	10	6000
088065	20	21-40	13	30	4	12	8000
088066	25	26-50	17	30	8	16	10000
088067	32	33-64	22	30	10	16	12500

Driving discs with carbide tothing, friction lining or diamond grain on request

A14

Driving discs, toothed, left-hand rotation

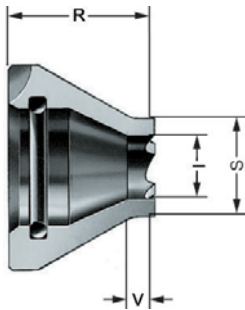

Item no.	Clamping circuit Ø S mm	Approx. turning range	l mm	R mm	V mm	Assoc. centre point Ø Y mm	Axial load max. N
088081	8	9-16	4,5	38	4	4	4000
088082	10	11-20	4,5	38	4	4	6000
088083	12	13-24	7	36	4	6	6000
088084	16	17-32	11	33	4	10	6000
088085	20	21-40	13	30	4	12	8000
088086	25	26-50	17	30	8	16	10000
088087	32	33-64	22	30	10	16	12500

Driving discs with carbide tothing on request, friction lining or diamond grain on request

A14

Driving discs, with interchangeable carbide driving plates 9,5 x 3,2, right-hand rotation

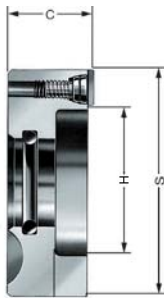

Item no.	Clamping circuit Ø S mm	Approx. turning range	H mm	C mm	Assoc. centre point Ø Y mm	Axial load max. N
088068	40	41-80	20	24	16	14000
088069	50	51-100	28	24	16	14000
088070	63	64-126	41	24	16	14000
088071	80	81-160	58	24	16	14000

A14

Driving discs, with interchangeable carbide driving plates 9,5 x 3,2, left-hand rotation

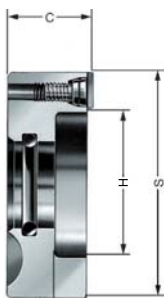

Item no.	Clamping circuit Ø S mm	Approx. turning range	H mm	C mm	Assoc. centre point Ø Y mm	Axial load max. N
088088	40	41-80	20	24	16	14000
088089	50	51-100	28	24	16	14000
088090	63	64-126	41	24	16	14000
088091	80	81-160	58	24	16	14000

Accessories CoK

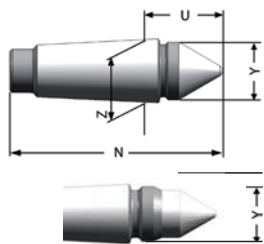
C15
Centres, CoK

Item no.	Clamping circuit Ø S mm	N mm	U mm	Y mm	Z mm	Workpiece weight max. g
088121	8-10	67,5	28	4	15	55
088122	12	67	28	6	15	75
088123	16	67	28	10	15	150
088124	20-32	64	25	12	15	250
085002	40-80	60	21	M 14x1,5	15	350

A14
Carbide driving plates, right- or left-hand rotation

Item no.	Size	Clamping circuit Ø mm
088209	9,5x3,2	40-80

A14
Carbide driving plates, right- and left-hand rotation

Item no.	Size	Clamping circuit Ø mm
087931	9,5x3,2	40-80

C15
Clamping spindle

Item no.	Size	Clamping circuit Ø mm
088205	M 5 x 8	40-80

C15
O-ring

Item no.	Size
006252	21,82x3,53

Special solutions

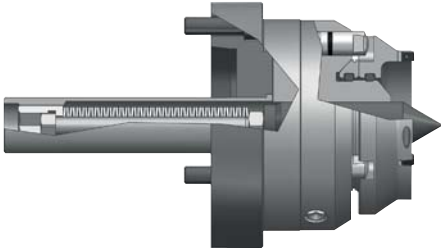

CoM - mechanical pressure compensation with driving disc

APPLICATION

For clamping large and heavy workpieces, as well as workpieces with extremely uneven faces.

TYPE

Basic body and adapter plate with disc spring package and morse taper or short taper.

CUSTOMER BENEFITS

- Resilient, stable centre point, axially adjustable
- Workpiece weight up to 500 kg
- Clamping circuit diameter 50-250 mm
- Interchangeable driving disc

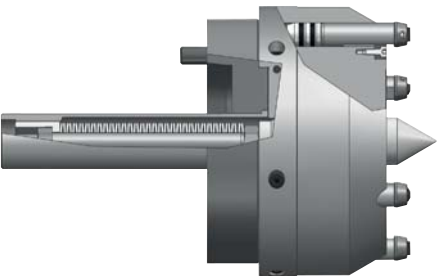

CoB - hydraulic pressure compensation with driving pin

APPLICATION

For clamping large and heavy workpieces, as well as workpieces with extremely uneven faces.

TYPE

Basic body with morse taper or short taper. Adapter plate with disc spring package.

CUSTOMER BENEFITS

- Resilient, stable centre point, axially adjustable
- Workpiece weight up to 500 kg / 1000 kg
- Clamping circuit diameter 63-160 mm

RÖHM GmbH

Heinrich-Röhm-Straße 50

89567 Sontheim/Brenz

Germany

Tel +49 7325 16 0

Fax +49 7325 16 510

info@roehm.biz

www.roehm.biz



driven by technology

Id.-Nr. 1178262 / 0915 AU